



CITY OF COLLEYVILLE CITY COUNCIL AGENDA

100 Main Street, Colleyville, Texas, 76034

TUESDAY, DECEMBER 16, 2025

**WORKSESSION
5:30 PM
EXECUTIVE CONFERENCE ROOM
THIRD FLOOR**

CALL TO ORDER

- WS-1** Presentation of 2025 Citizen Survey Results
- WS-2** Economic Development Update
- WS-3** Discussion of the December 16, 2025, City Council regular agenda items

1. EXECUTIVE SESSION - In accordance with Texas Government Code, Chapter 551, Subchapter D

Section 551.071 - Legal - Consultation with the City Attorney regarding items on the agenda or for matters in which the duty of the attorney to the governmental body under the Texas Disciplinary Rules of Professional Conduct of the State Bar of Texas clearly conflicts with Chapter 551 of the Texas Code

Section 551.072 - Real Estate - Deliberate the purchase, exchange, lease, or value of real property for City facilities

Section 551.087 - Economic Development - Discuss or deliberate regarding commercial or financial information the City has received from business prospects the City seeks to have locate, stay, or expand in the City and with which the City is conducting economic development negotiations; deliberate the offer of a financial or other incentive to a business prospect

**REGULAR MEETING
7:00 P.M.
CITY COUNCIL CHAMBERS**

INVOCATION: Pastor Josh Anderson, Colleyville Presbyterian

PLEDGE OF ALLEGIANCE: City Attorney

2. EXECUTIVE SESSION READING AND PUBLIC HEARING: CONSIDER AND TAKE ANY ACTION(S) NECESSARY RELATIVE TO ITEMS DISCUSSED IN EXECUTIVE SESSION - RESOLUTION R-25-5101

3. ANNOUNCEMENTS, PROCLAMATIONS, AND PRESENTATIONS

Proclamation in recognition of December as Season of Small Business - Mayor Bobby Lindamood and Chelsea Rose, Colleyville Community Engagement and Economic Development

Announcement of the 2025 Community Decorated Christmas Trees winners

4. CONSENT: READING AND PUBLIC HEARING - RESOLUTION R-25-5102

4a Approval of the minutes of the regular City Council meeting of December 2, 2025

4b Approval of an Interlocal Agreement and funding for the Metroport Teen Court Program

5. ITEMS NOT FOR CITY COUNCIL ACTION

5a Monthly Financial Report - November 2025

6. ORDINANCE(S): SECOND READING AND PUBLIC HEARING**6a Ordinance O-25-2356**

Consideration of a Special Use Permit for an Accessory Building for Lot 3, Block 1, Beldon Hollow, located at 4905 Beldon Trail, Case ZC25-029

7. CITIZEN COMMENTS**8. REPORTS**

Colleyville Center Advisory Committee Minutes — August 17, 2025

Planning and Zoning Commission Minutes — November 10, 2025

Planning and Zoning Commission Worksession Minutes — November 24, 2025

9. ACTION/RESOLUTION: DISCUSSION AND CONSIDERATION OF A RESOLUTION RATIFYING COUNCIL AGENDA ACTION FOR TUESDAY, DECEMBER 16, 2025 - READING AND PUBLIC HEARING - RESOLUTION R-25-5103**10. ADJOURNMENT**

I hereby certify this agenda was posted on City Hall bulletin boards on Wednesday, December 10, 2025, by 5:00 p.m.

Christine Loven, TRMC
City Secretary

A quorum of any Colleyville board, commission, or committee may be present at this meeting. Any matter on this agenda may, at the discretion of the governing body, be opened for public comment and discussion.

If you plan to attend this public meeting and have a disability that requires special accommodations, please advise the City Secretary at least 48 hours in advance at 817.503.1130, and reasonable accommodations will be made to assist you.



CITY OF COLLEYVILLE CITY COUNCIL BRIEFING

Agenda Number WS-1

Agenda Date 12/16/2025

Type Worksession

Department City Manager

Title

Presentation of 2025 Citizen Survey Results

Explanation

City staff will present the results of the 2025 Citizen Survey.

Attachments

1. 2025 Citizen Survey Results Presentation

2025 City of Colleyville Citizen Survey



City Council Worksession
December 16, 2025

NATIONAL
SERVICE
RESEARCH

MARKET RESEARCH

Survey Administration

- Consultant: Andrea Thomas, Owner, National Service Research

Responses

- 2025 Survey: 1,036 responses (all online)
- 2022 Survey: 1,841 responses (all online)
- 2019 Survey: 1,317 responses (all online)
- 2017 Survey: 907 responses (all online)
- 2014 Survey: 1,323 responses (825 mail; 498 online)
- 2012 Survey: 1,665 responses (1,070 mail; 595 online)
- 2010 Survey: 1,677 responses (1,412 mail; 265 online)

Communication Preferences



1a. How do you currently get information about the City of Colleyville?

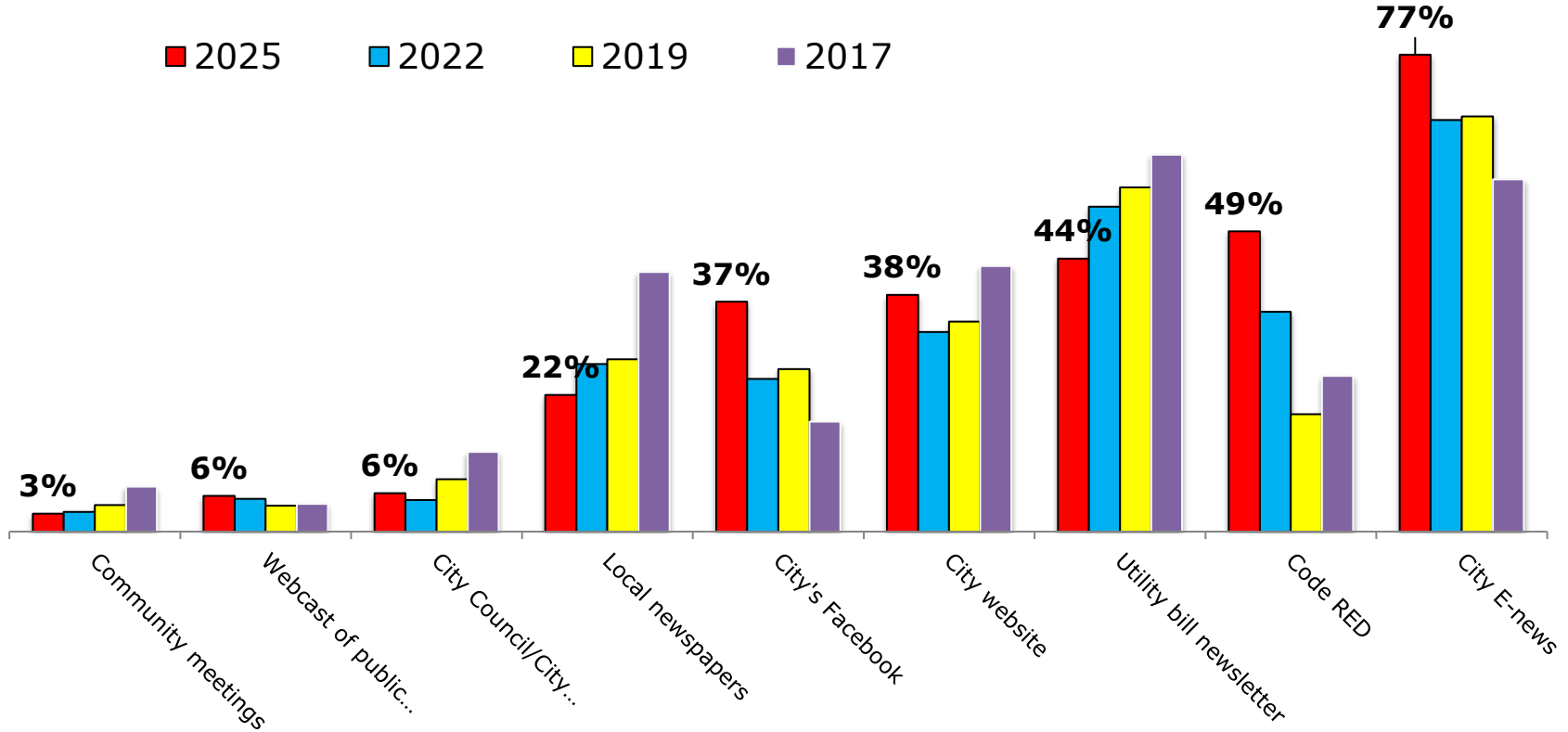

Satisfaction with Communication



**1b. Please indicate your level of satisfaction with the following:
Keeping citizens informed about City business**

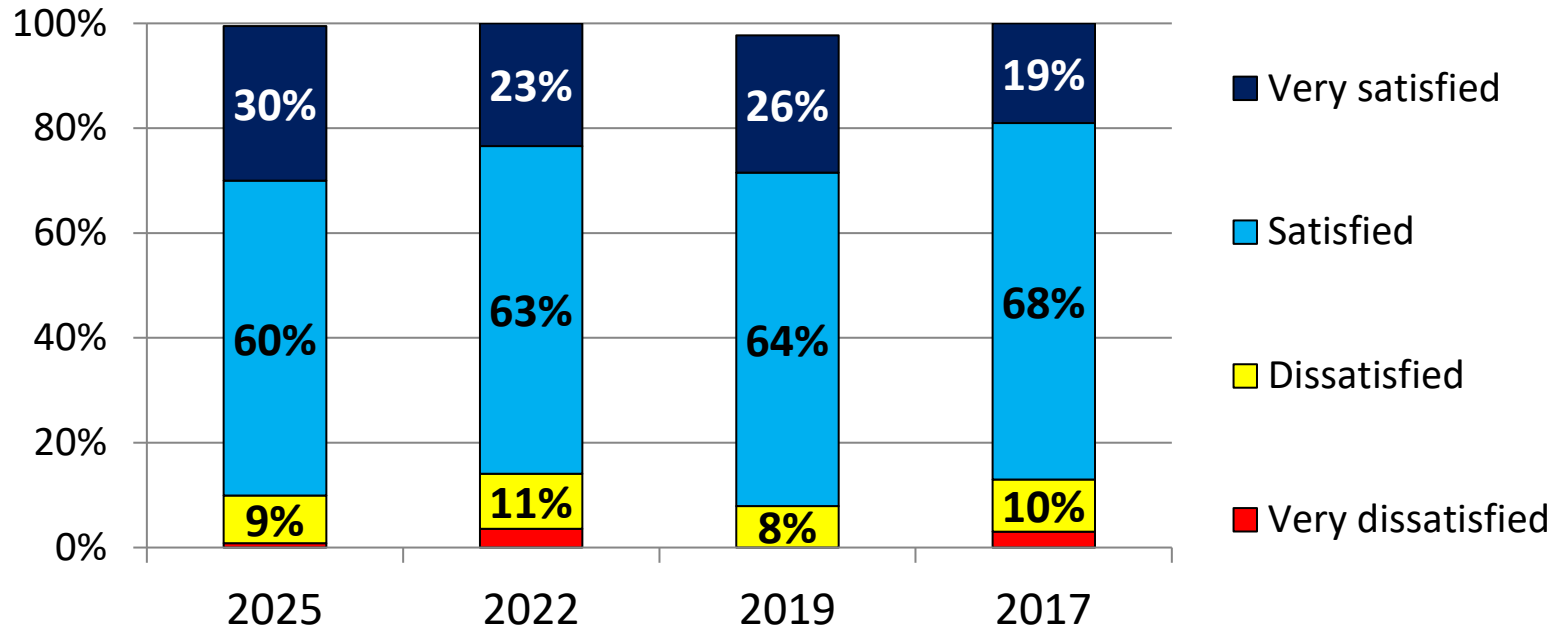

Other Communication Needs



Q1c. Based upon your preferred method of receiving communications, what methods of communication should the City focus on?

(Select your TOP THREE)

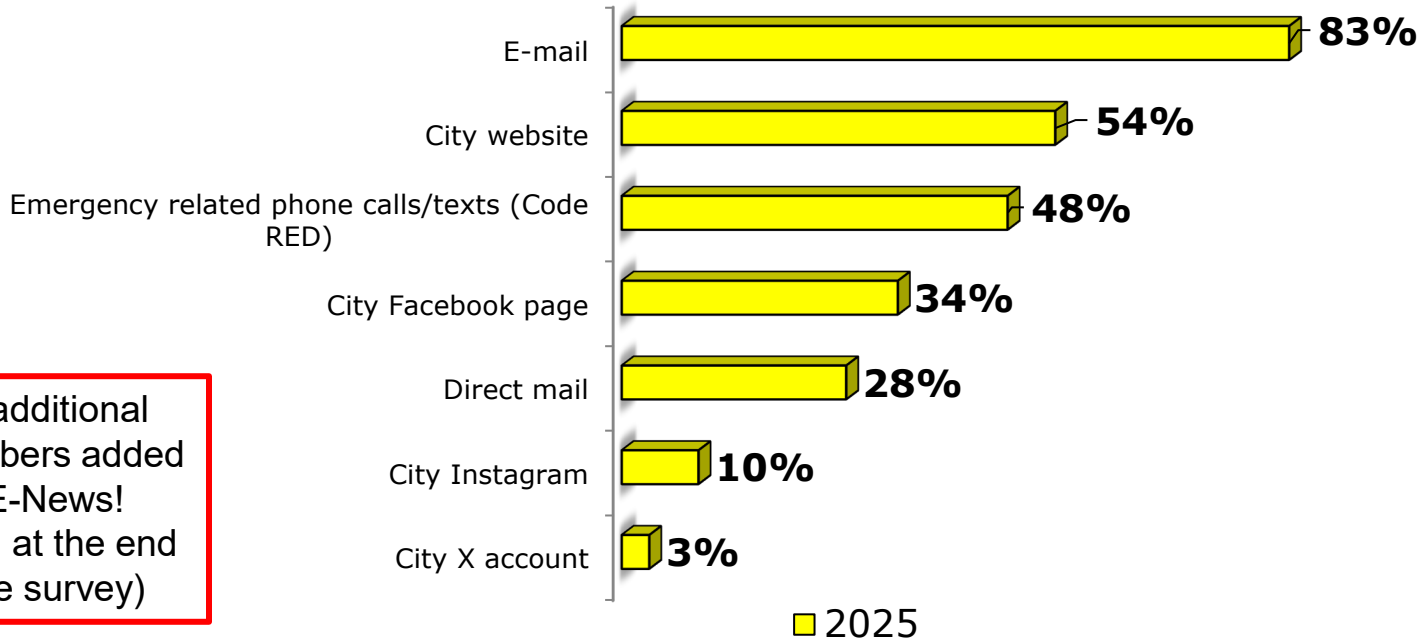

105 additional subscribers added to E-News! (option at the end of the survey)

Satisfaction with City Performance



Q2. How satisfied are you with the City of Colleyville's performance for each of the following areas?

COMBINED PERCENTAGES: VERY SATISFIED/SATISFIED (Excludes "No Opinion" responses)

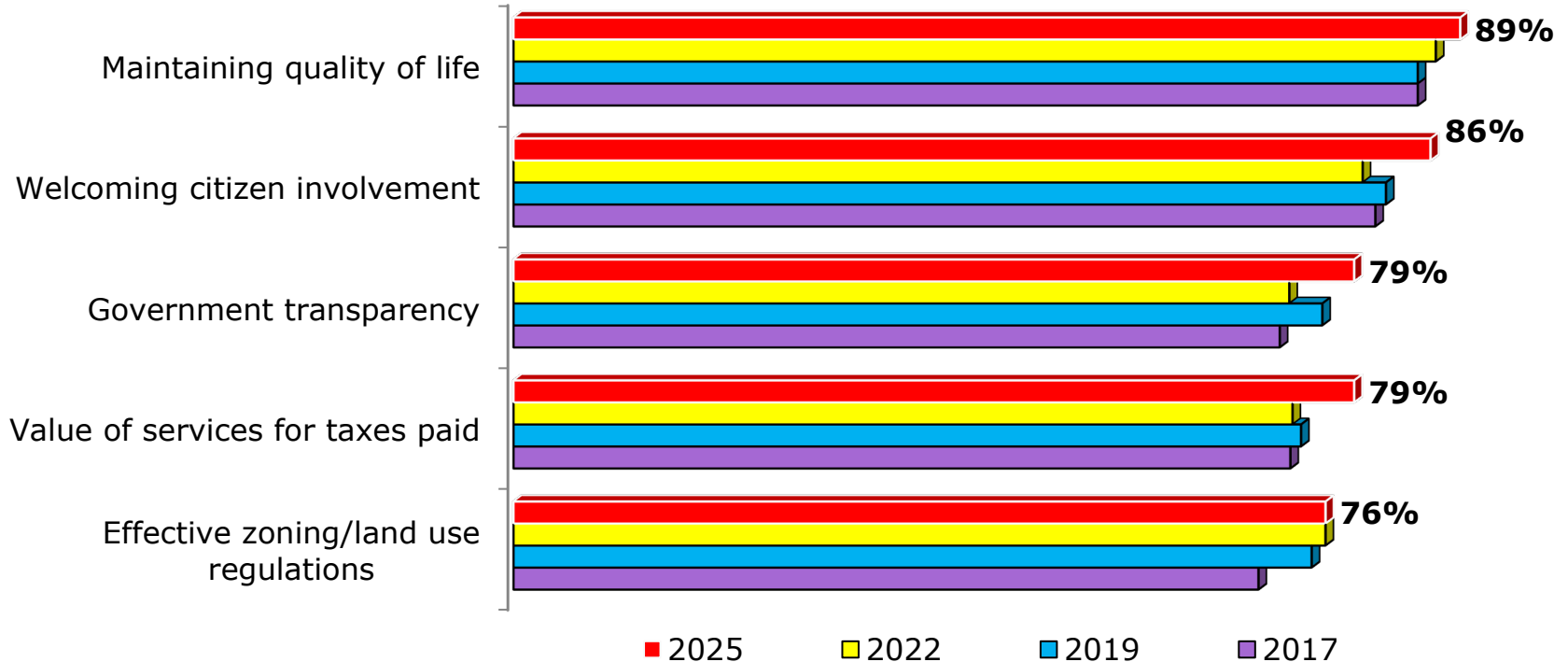

Satisfaction with City Performance



Q2. How satisfied are you with the City of Colleyville's performance for each of the following areas?

COMBINED PERCENTAGES: VERY SATISFIED/SATISFIED (Excludes "No Opinion" responses)

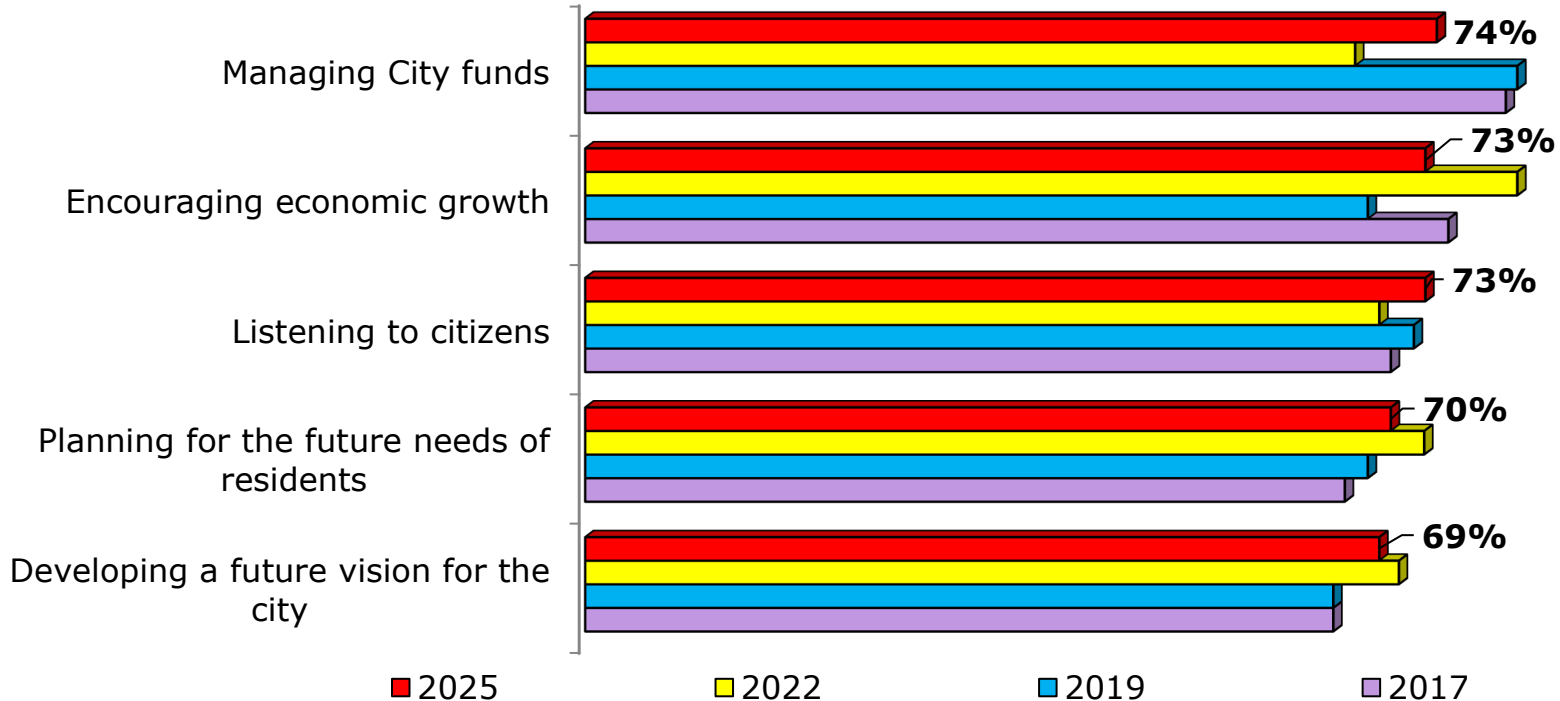

Satisfaction with City Performance



Q2. How satisfied are you with the City of Colleyville's performance for each of the following areas?

COMBINED PERCENTAGES: VERY SATISFIED/SATISFIED (Excludes "No Opinion" responses)

Satisfaction with City Performance	2025 Very Satisfied + Satisfied %	2022 Very Satisfied + Satisfied %	2019 Very Satisfied + Satisfied %	2017 Very Satisfied + Satisfied %	2014 Very Satisfied + Satisfied %
Maintaining quality of life	89%	87%	85%	85%	91%
Welcoming citizen involvement	86%	80	82	81	88
Government transparency	79%	73	76	72	84
Value of services for taxes paid	79%	73	74	73	81
Effective zoning and land use regulations	76%	76	75	70	78
Managing City funds	74%	67	81	80	87
Encouraging economic growth	73%	81	68	75	74
Listening to citizens	73%	69	72	70	81
Planning for the future needs of residents	70%	73	68	66	77
Developing a future vision for the City	69%	71	65	65	71

City Employee Contact



Q3. If you have had contact with a City of Colleyville employee within the past year, how satisfied were you with the following?

COMBINED PERCENTAGES: VERY SATISFIED/SATISFIED (Excludes "No Opinion/NA")

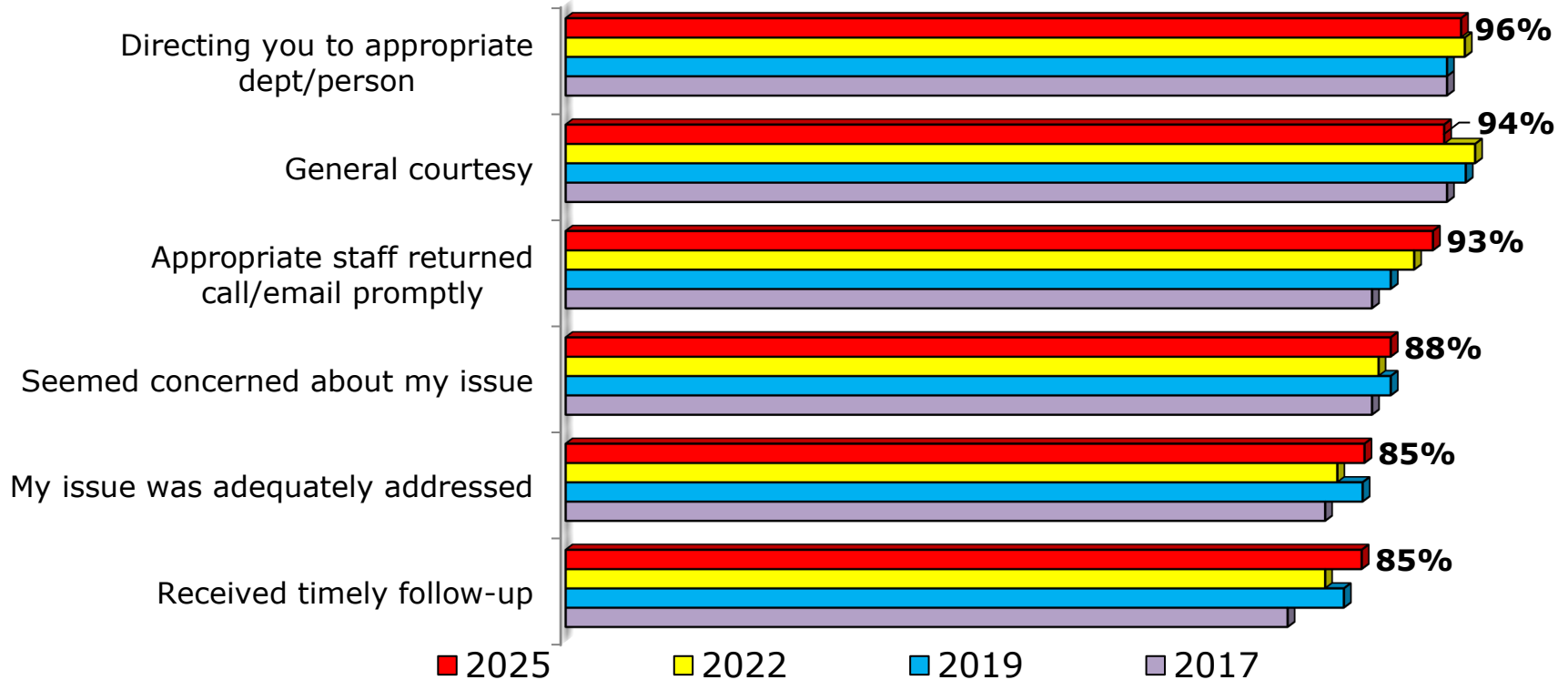

City Employee Contact



Q3. If you have had contact with a City of Colleyville employee within the past year, how satisfied were you with the following?

(Excludes "No Opinion/NA")

City Employee Contact	2025 Very Satisfied + Satisfied %	2022 Very Satisfied + Satisfied %	2019 Very Satisfied + Satisfied %	2017 Very Satisfied + Satisfied %	2014 Very Satisfied + Satisfied %
Directing you to the appropriate department/person	96%	96	94	94	96
General courtesy	94	97	96	94	97
Appropriate staff returned my call/email promptly	93	91	88	86	90
Seemed concerned about my issue	88	87	88	86	89
My issue was adequately addressed	85	82	85	81	84
Received timely follow-up from City to ensure my issue was addressed	85	81	83	77	81

Q4a. How satisfied are you with the overall quality of life in Colleyville: (COMBINED RESPONSES: very satisfied and satisfied, excludes "No Opinion" responses)

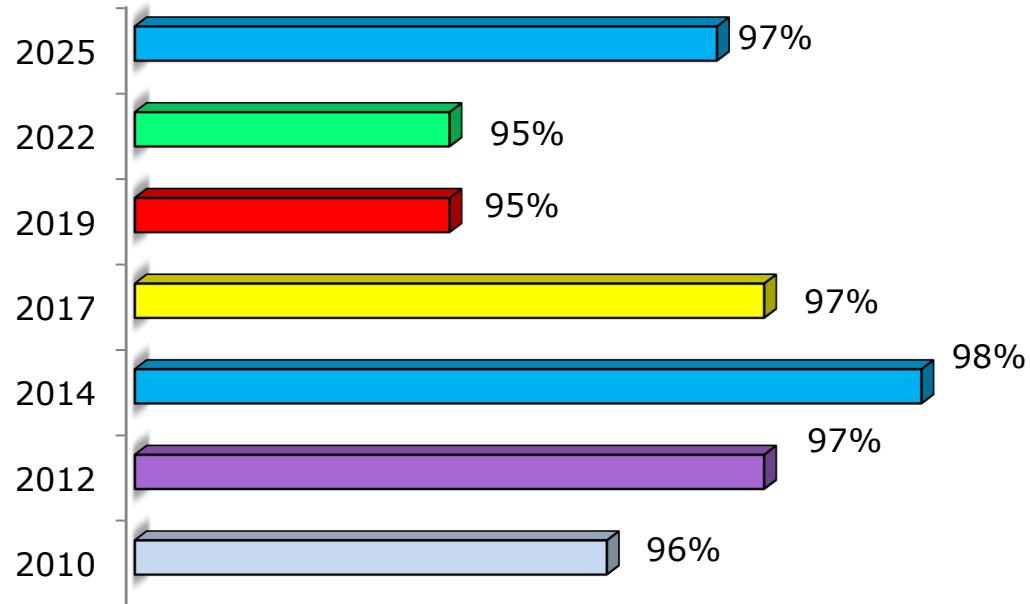

Q4a. Please indicate your level of satisfaction with Colleyville(s):

(Excludes "No Opinion" responses)

Quality of Life in Colleyville	Satisfaction			
	2025 Very satisfied + satisfied	2022 Very satisfied + satisfied	2019 Very satisfied + satisfied	2017 Very satisfied + satisfied
Overall safety of Colleyville	98%	98%	97%	96%
Overall quality of life	97	95	95	97
As a place to live	96	95	97	98
As a place to raise a family	96	93	98	98
Appearance of your neighborhood	94	92	91	91
Overall quality of city services	93	91	90	89
Overall appearance of Colleyville	93	86	82	81
As a place to retire	88	84	79	80
Overall image/reputation	90	83	87	90
As a place to work	82	82	75	81
As a place to do business	69	78	64	76

Q4b. During the time you have lived here, do you think that as a community Colleyville has:

(Excludes "No Opinion" responses)

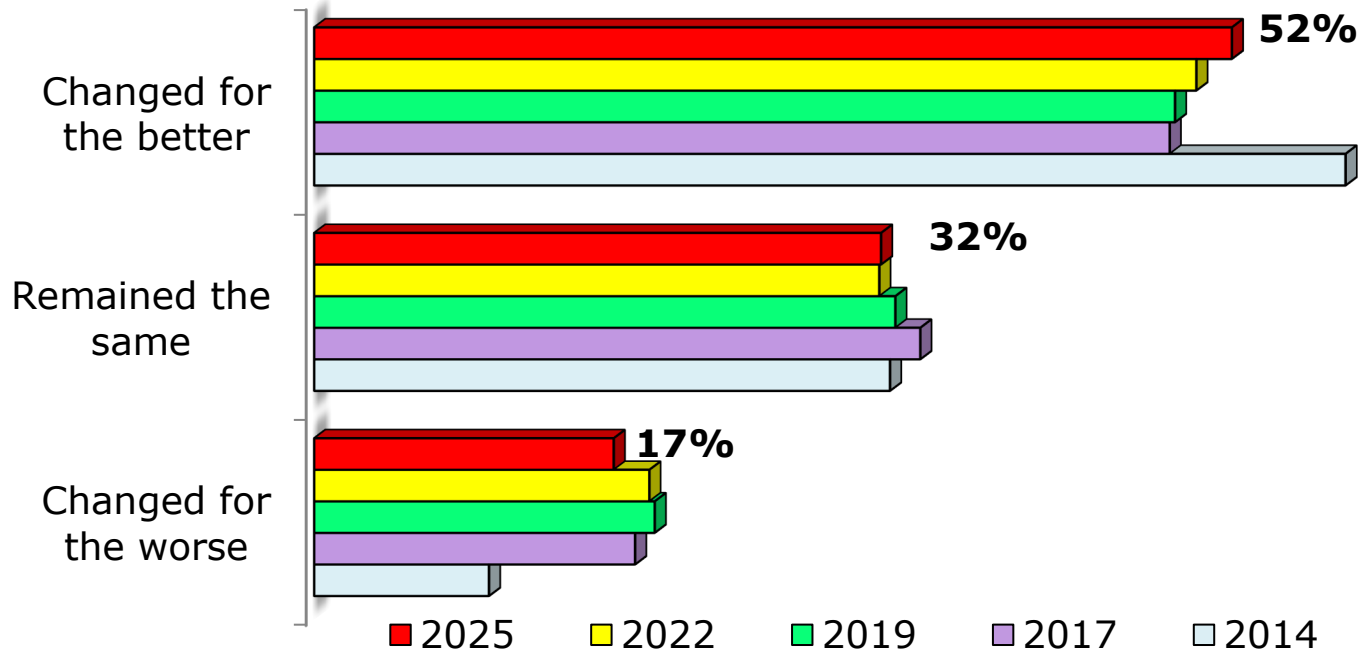

Satisfaction with City Services



Q5. Please indicate your level of satisfaction with the following:

COMBINED PERCENTAGES: VERY SATISFIED/SATISFIED (Excludes "no opinion" responses)

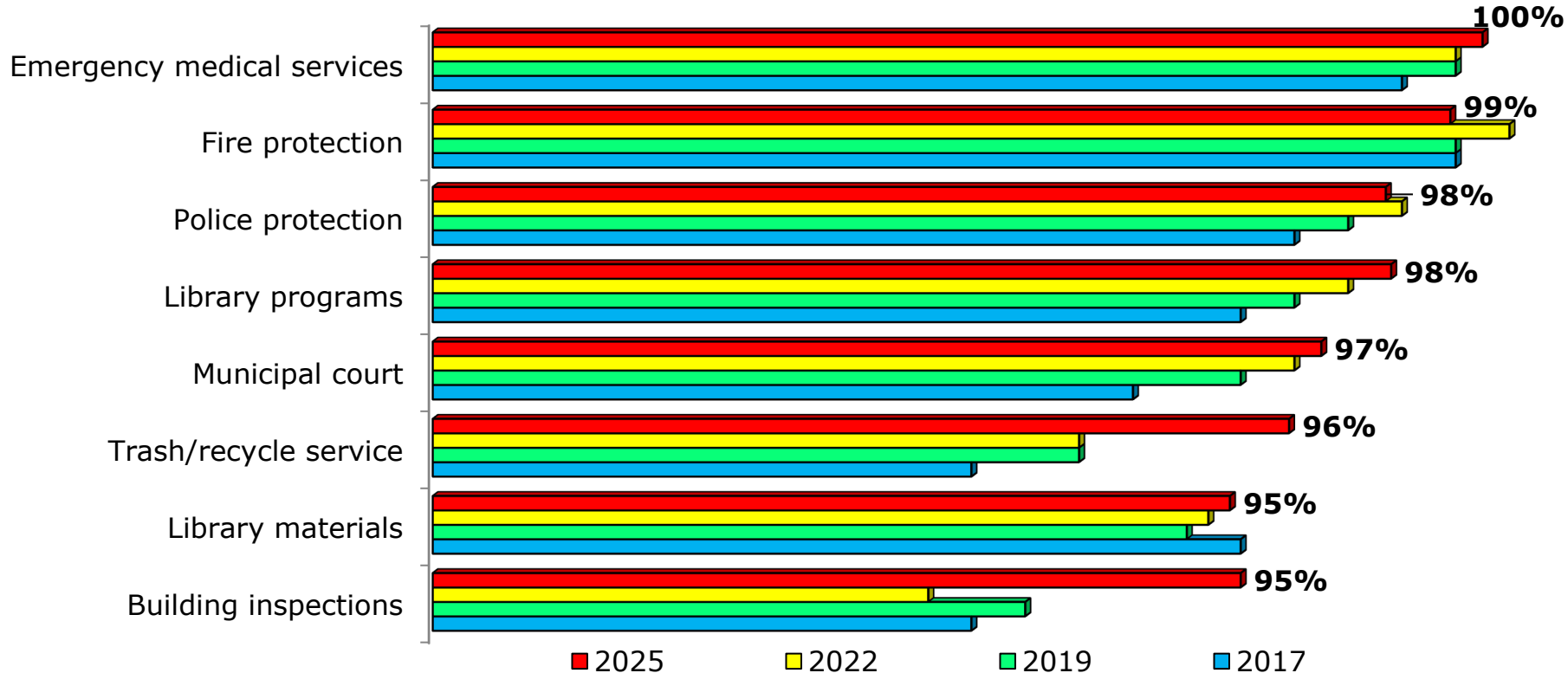

Satisfaction with City Services



Q5. Please indicate your level of satisfaction with the following:

COMBINED PERCENTAGES: VERY SATISFIED/SATISFIED (Excludes "no opinion" responses)

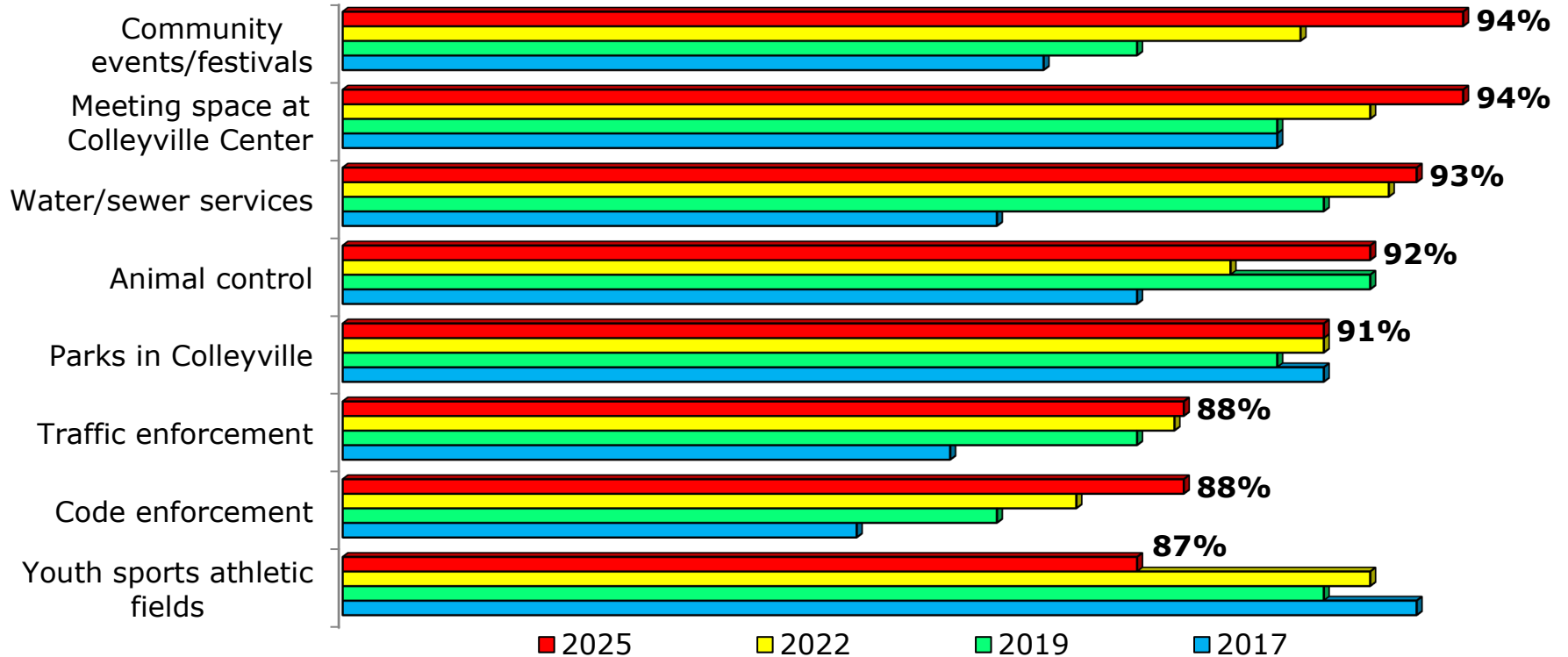

Satisfaction with City Services



Q5. Please indicate your level of satisfaction with the following:

COMBINED PERCENTAGES: VERY SATISFIED/SATISFIED (Excludes "no opinion" responses)

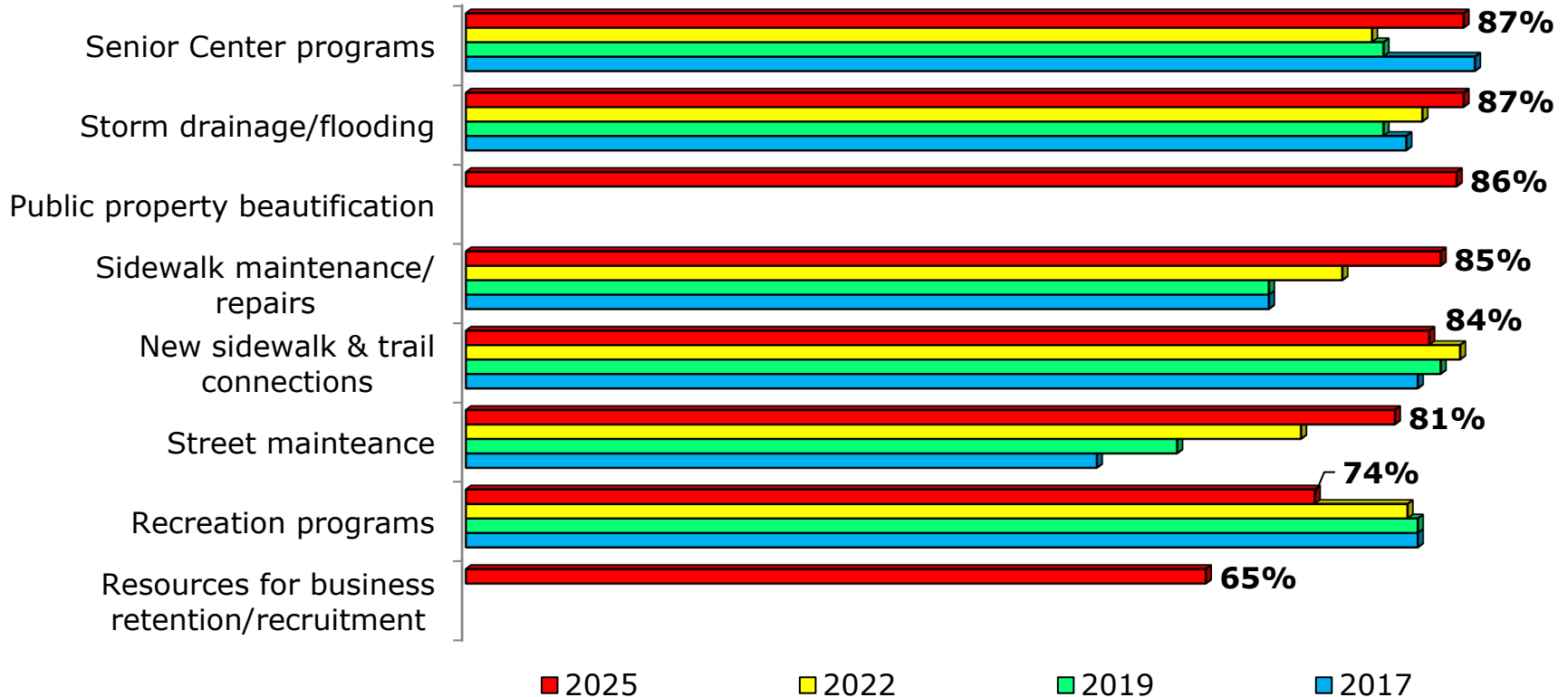

Satisfaction with City Services



Q5. Please indicate your level of satisfaction with the following:

TOP 13 (Excludes "no opinion" responses)

Satisfaction with City Services	2025 Combined Satisfaction %	2022 Combined Satisfaction %	2019 Combined Satisfaction %	2017 Combined Satisfaction %
1-Emergency medical services	100%	99%	99%	98%
2-Fire protection	99	100	99	99
3-Police protection	98	98	97	96
4-Library programs	98	97	96	95
5-Municipal court	97	96	95	93
6-Trash/recycle service	96	92	92	90
7-Library materials	95	94	94	95
8-Building inspections	95	89	91	90
9-Community events/festivals	94	91	87	85
10-Meeting space at Colleyville Center (for rental)	94	92	90	90
11-Water/sewer services	93	92	91	84
12-Animal control	92	89	92	87
13-Parks in Colleyville	91	91	90	91

Satisfaction with City Services



Q5. Please indicate your level of satisfaction with the following:

NEXT 14-24 (Excludes "no opinion" responses)

Satisfaction with City Services	2025 Combined Satisfaction %	2022 Combined Satisfaction %	2019 Combined Satisfaction %	2017 Combined Satisfaction %
14-Traffic enforcement	88%	88%	87%	83%
15-Code enforcement	88	86	84	81
16-Youth sports athletic fields	87	92	91	93
17-Senior Center programs	87	79	80	88
18-Storm drainage/flooding	87	83	80	82
19-Public property beautification	86	-	-	-
20-Sidewalk maintenance/repairs	85	76	70	70
21-New sidewalk & trail connections	84	87	85	83
22-Street maintenance/repairs	81	73	62	55
23-Recreation programs	74	82	83	83
24-Reources allocated toward business retention/recruitment	65	--	-	-

Economic Development



Q6a. Should the City prioritize purchasing commercial property for the purpose of commercial redevelopment?

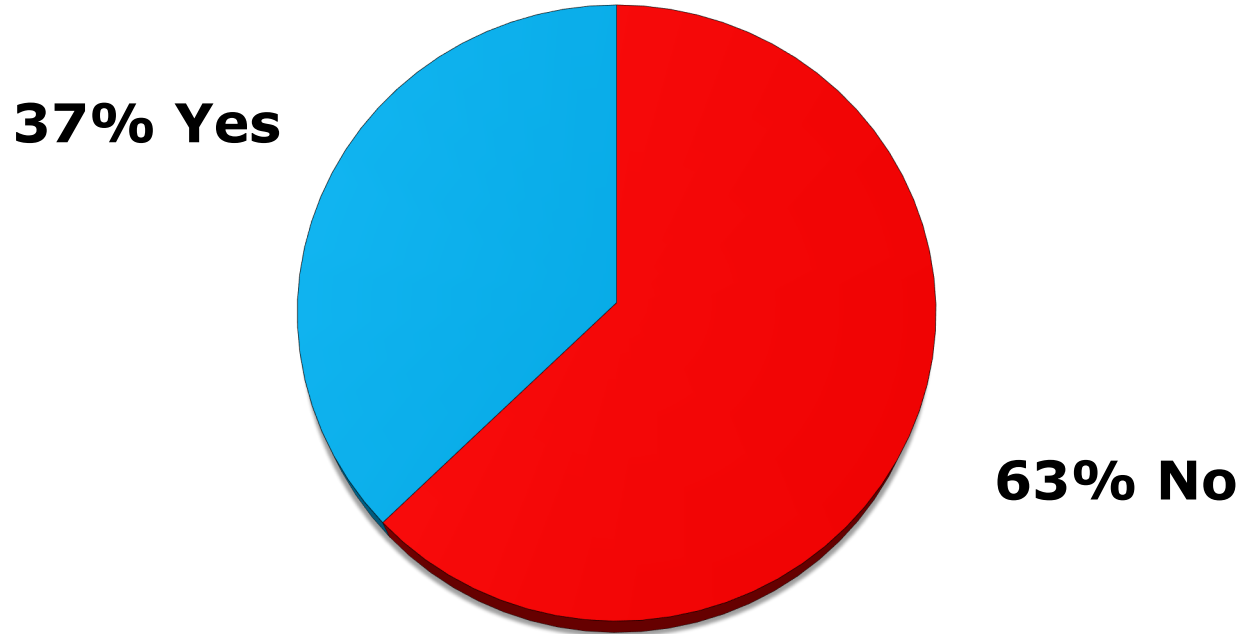

Economic Development



Q6b. How would you prioritize the funding utilized for purchasing commercial property for the purpose of redevelopment?

In ranked order



Economic Development



Q6c. If purchasing commercial property and buildings for the purpose of commercial redevelopment were a priority, what amount of funding should be directed for this purpose?

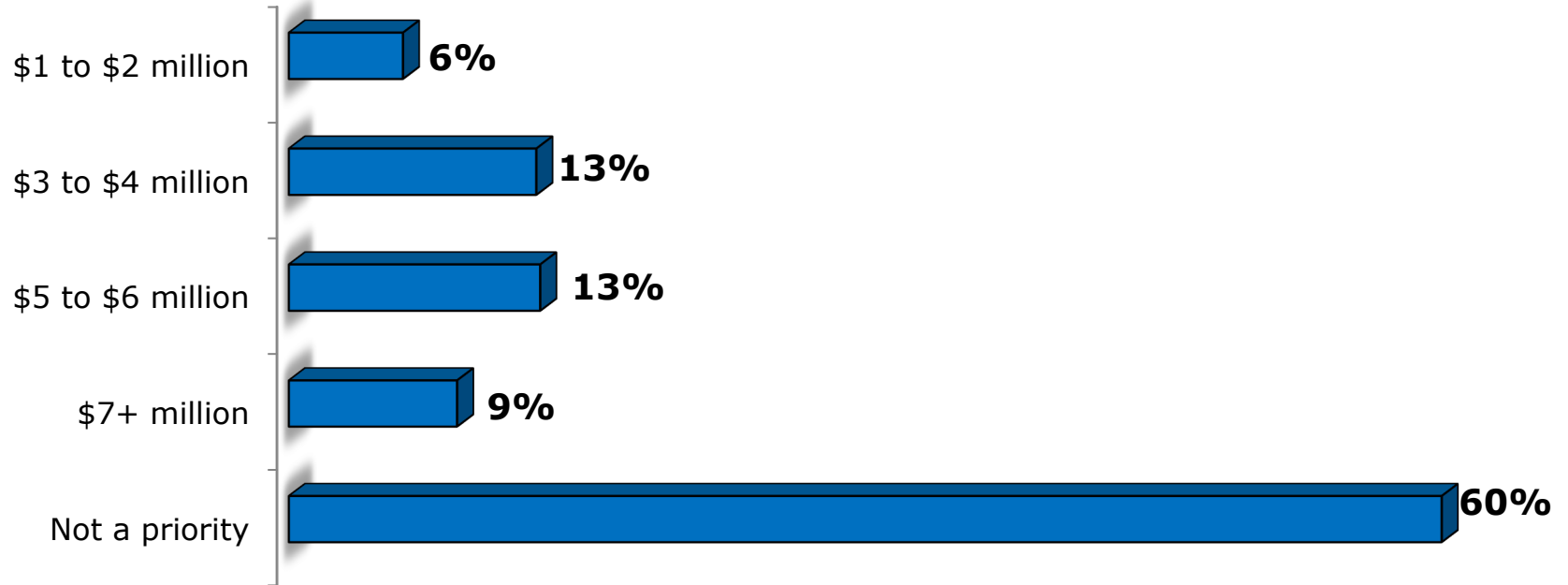

Q7a. Should the City pursue the purchase of open space?

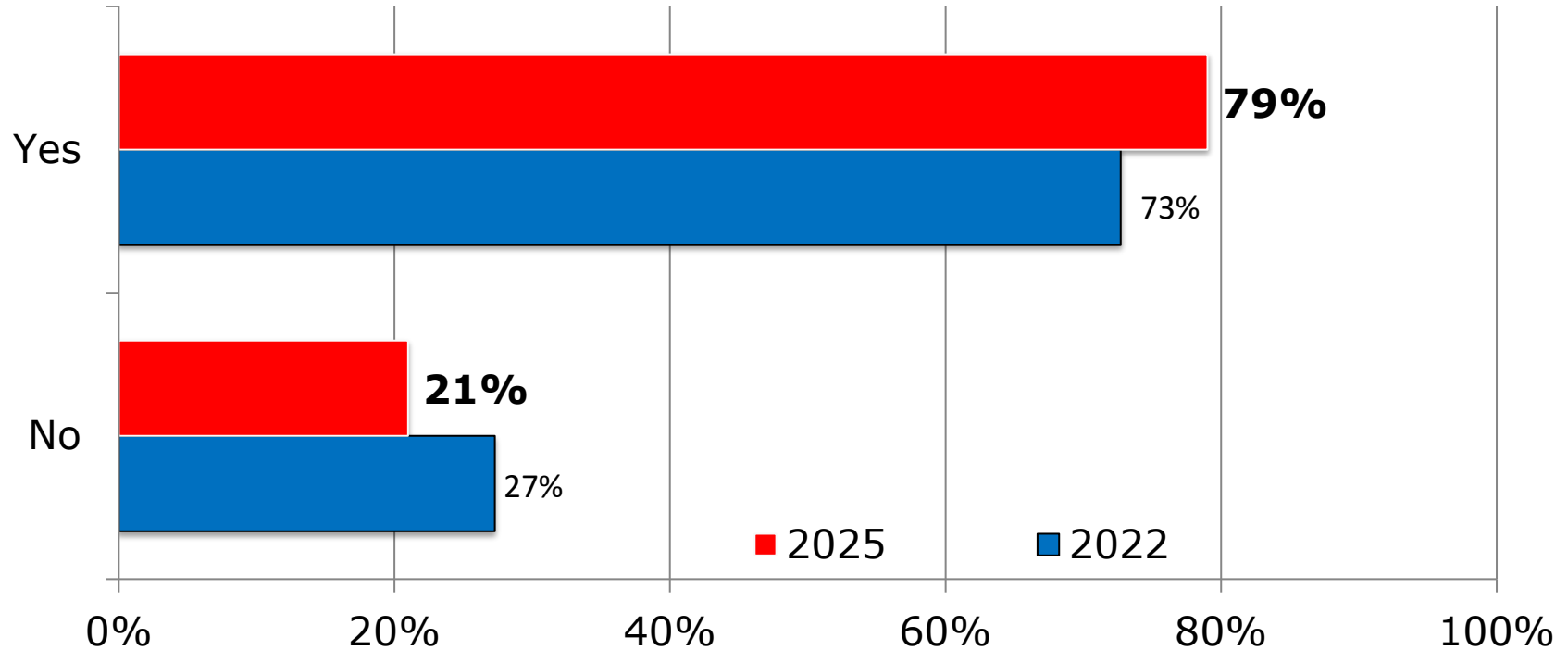

**Q7b. Do you agree with the following statement:
I am willing to pay more in property taxes to preserve more open space**

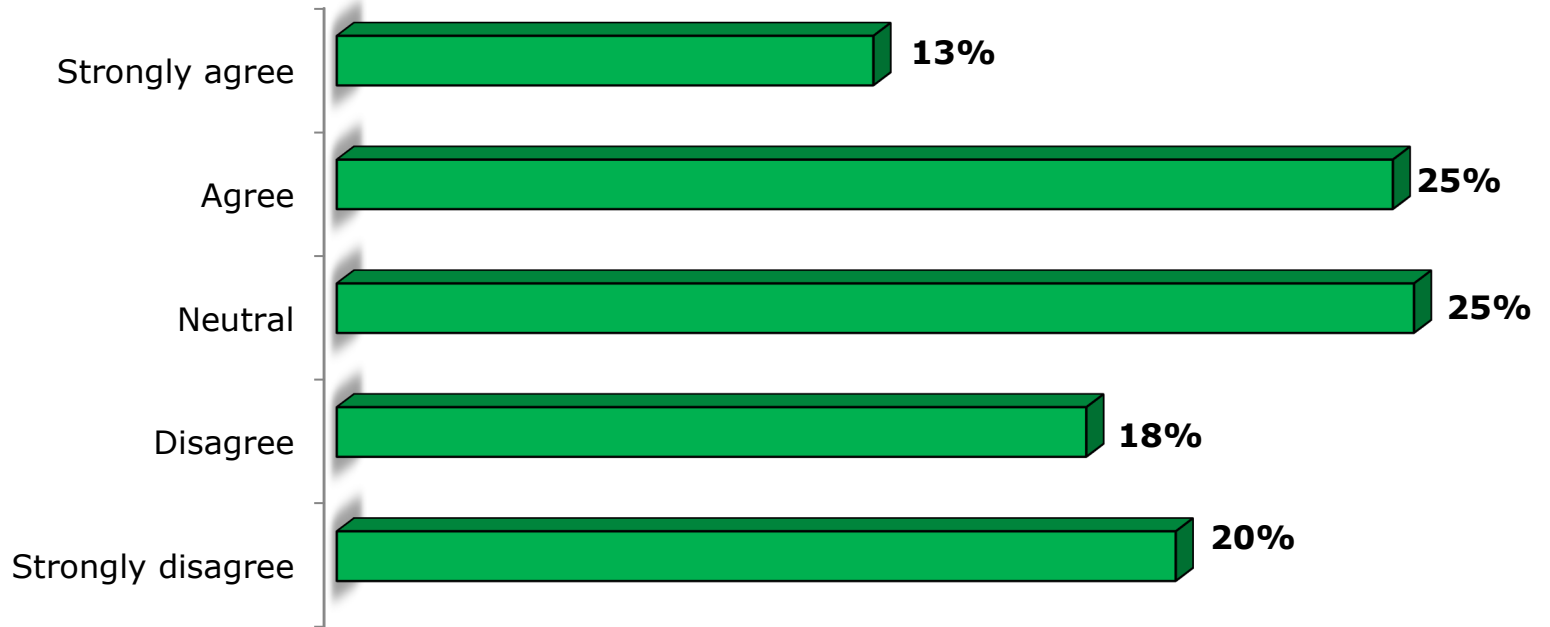

Open Space



Q7c. If purchasing property for the purpose of preserving open space was a priority, what amount of funding should be directed for this purpose?

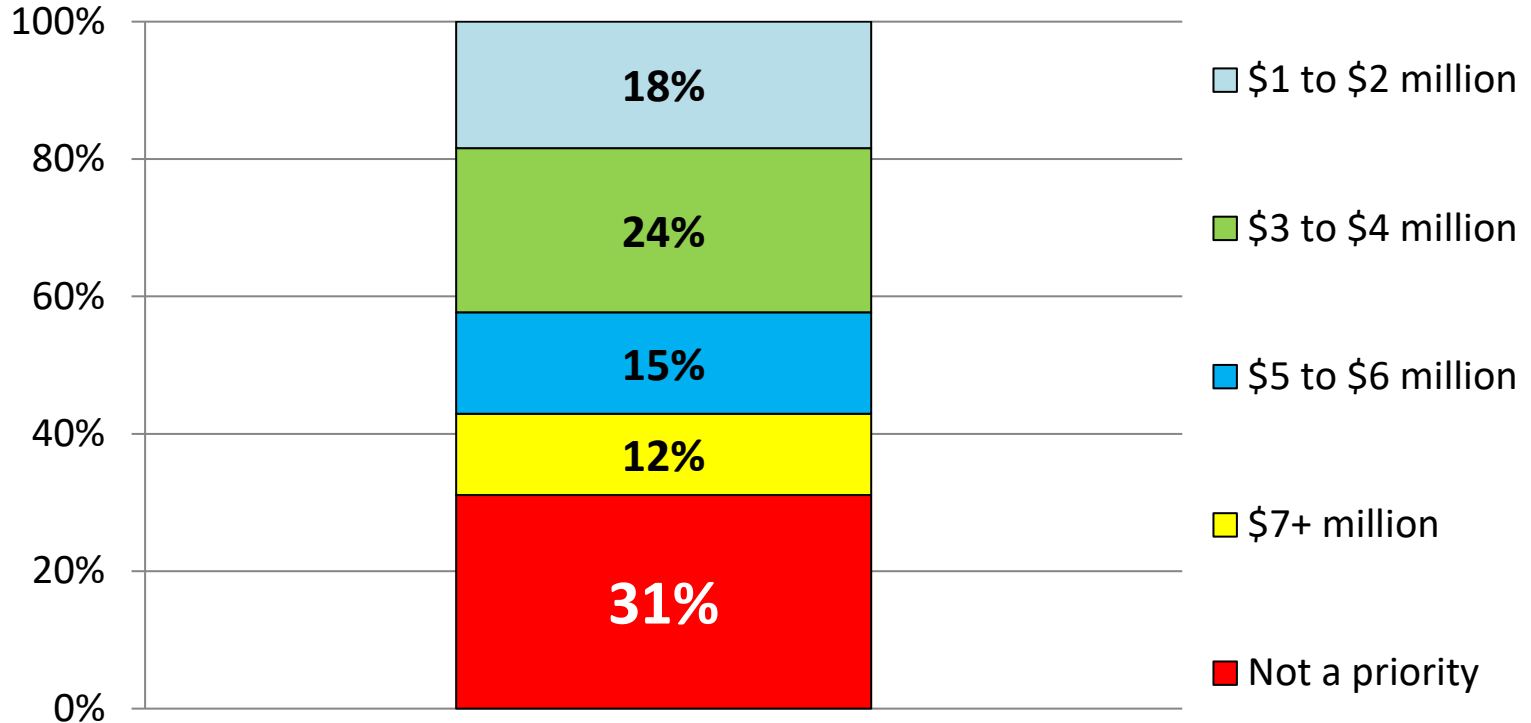

Q7d. How would you prefer newly acquired property be utilized?

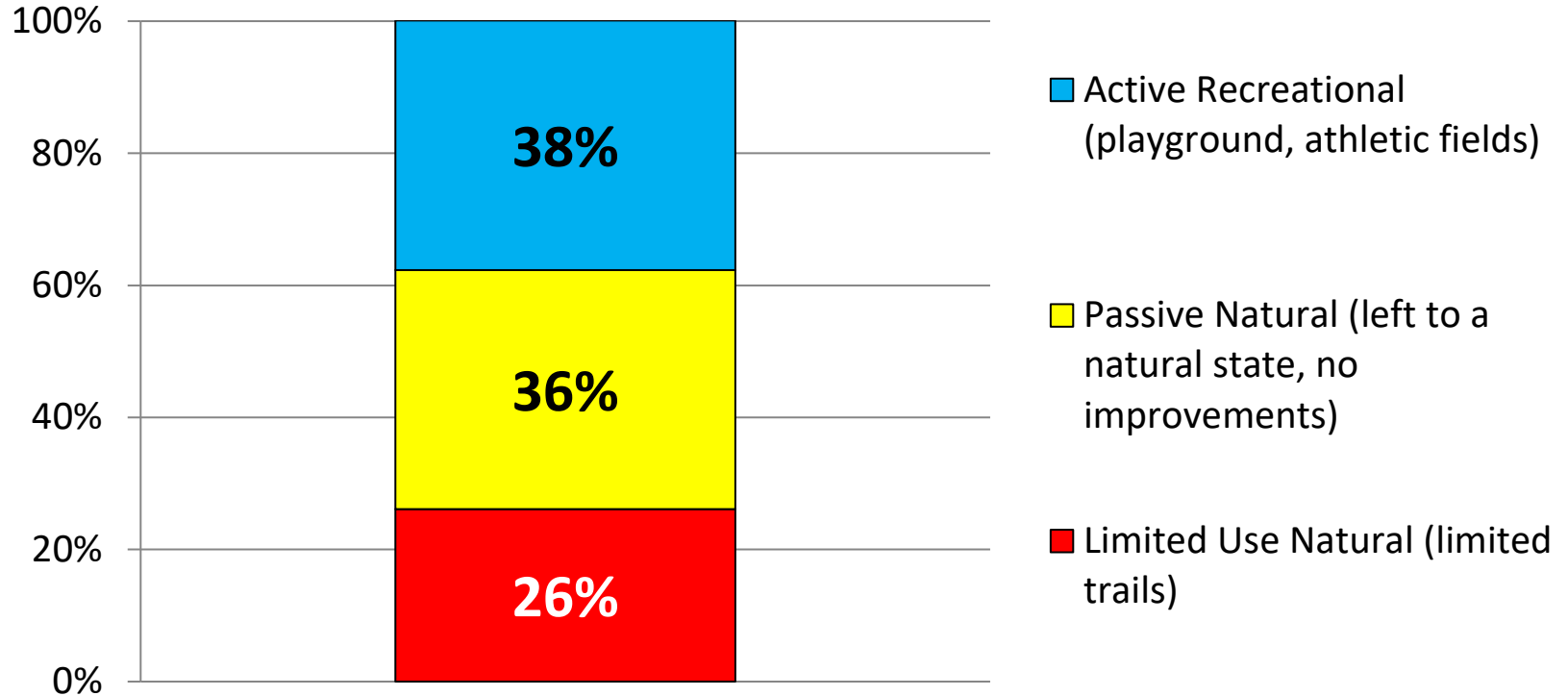

Q8a. What would you like to see more of in the Village?

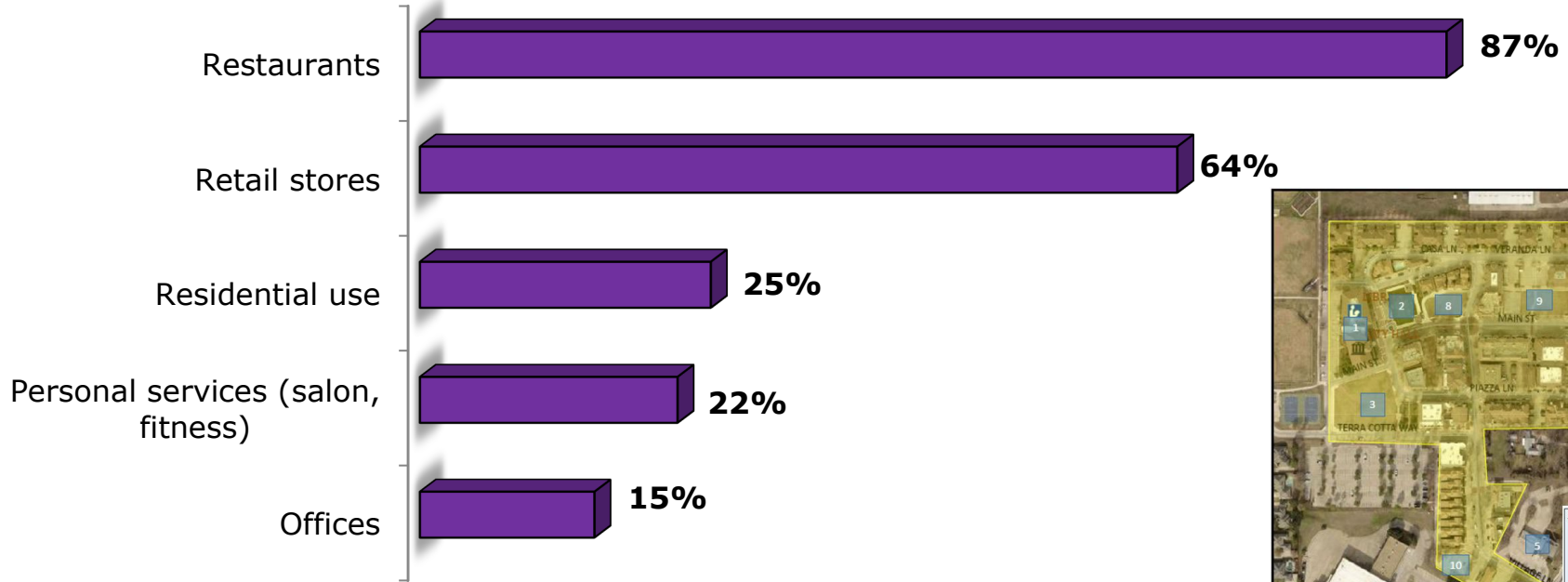

Q8b. How should the City support that effort utilizing TIF (economic development) dollars? In Rank Order

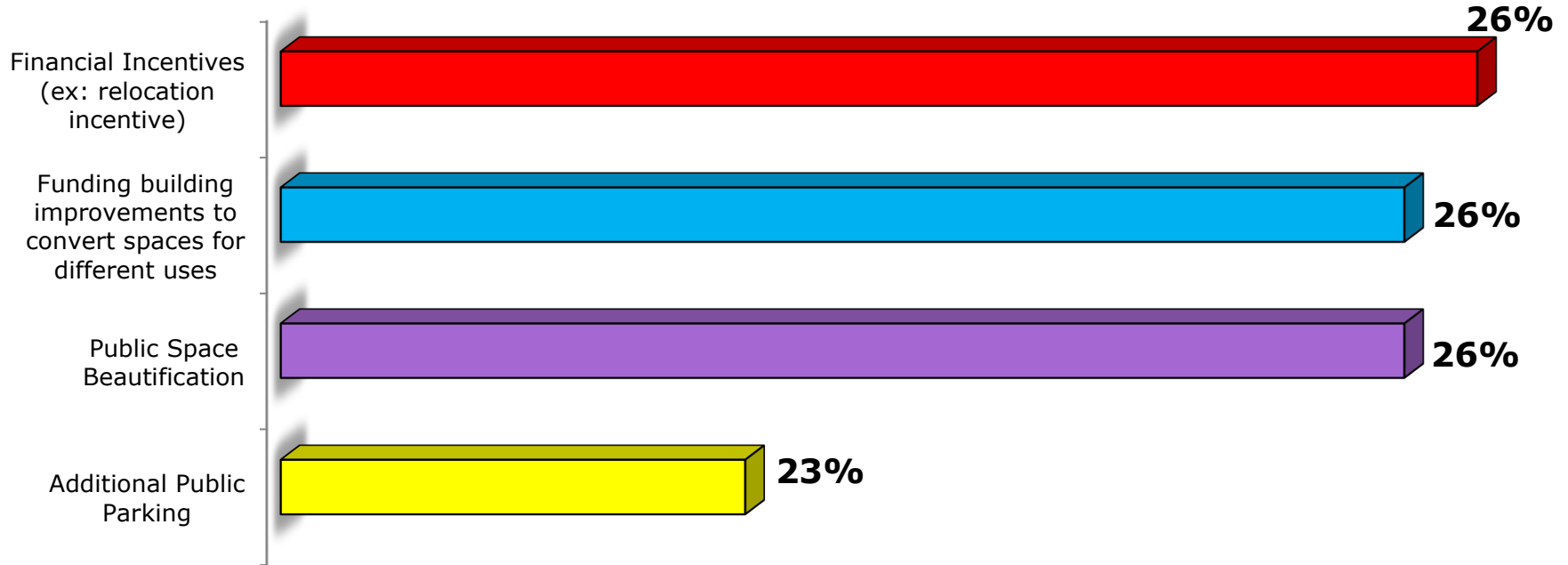

Community Events Feedback



Q9a. City events build a sense of community.

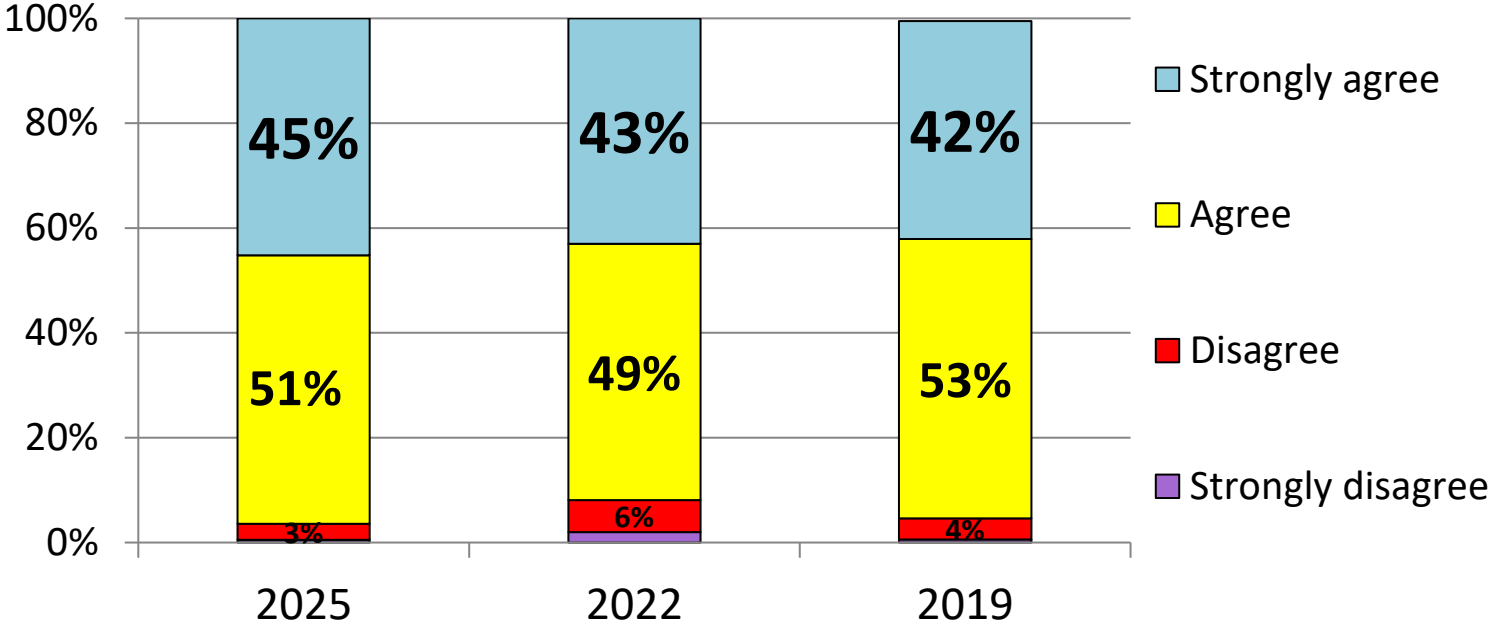

Community Events Feedback



Q8c. How many City events have you attended in the last 12 months?

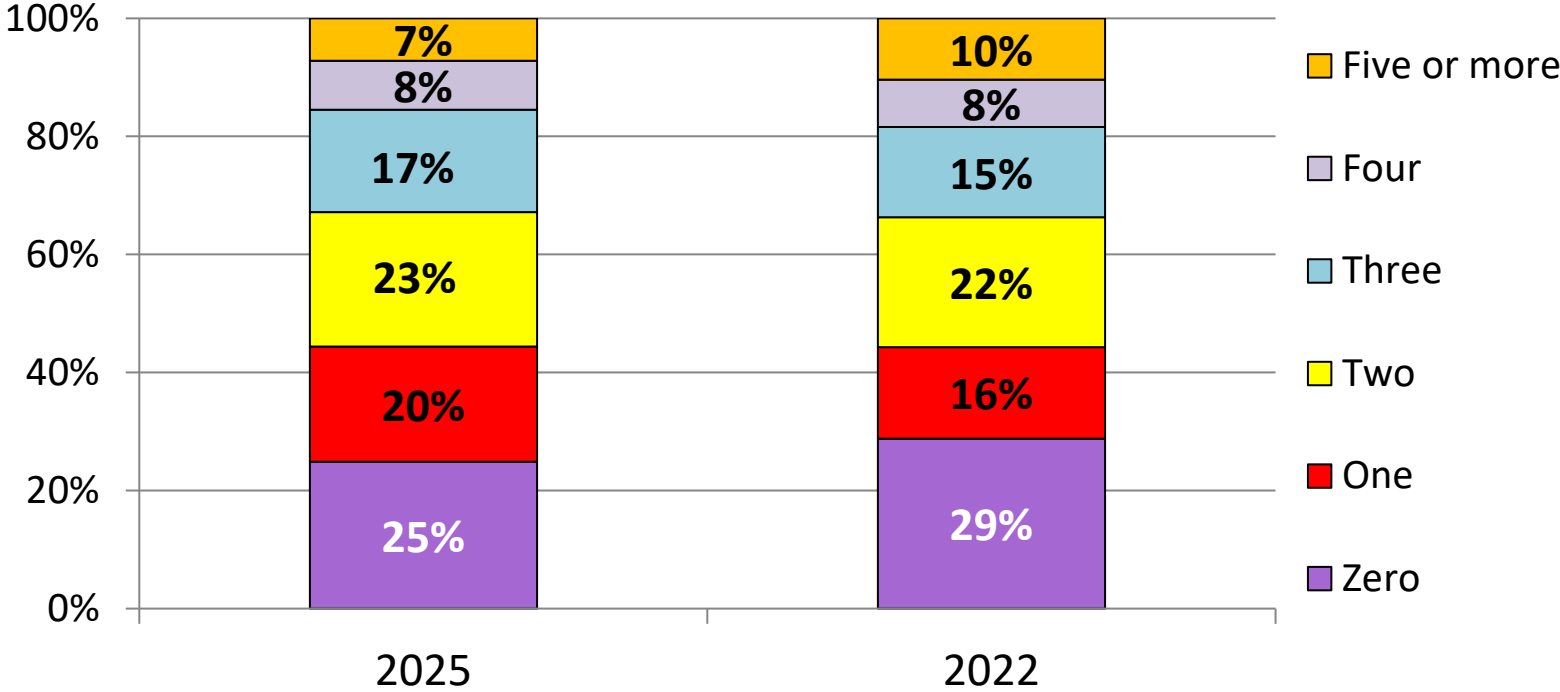

New question in 2022 Citizen Survey

Community Events Feedback



Q9c. Indicate your level of satisfaction for the events you attended.

Very Satisfied
Satisfied %

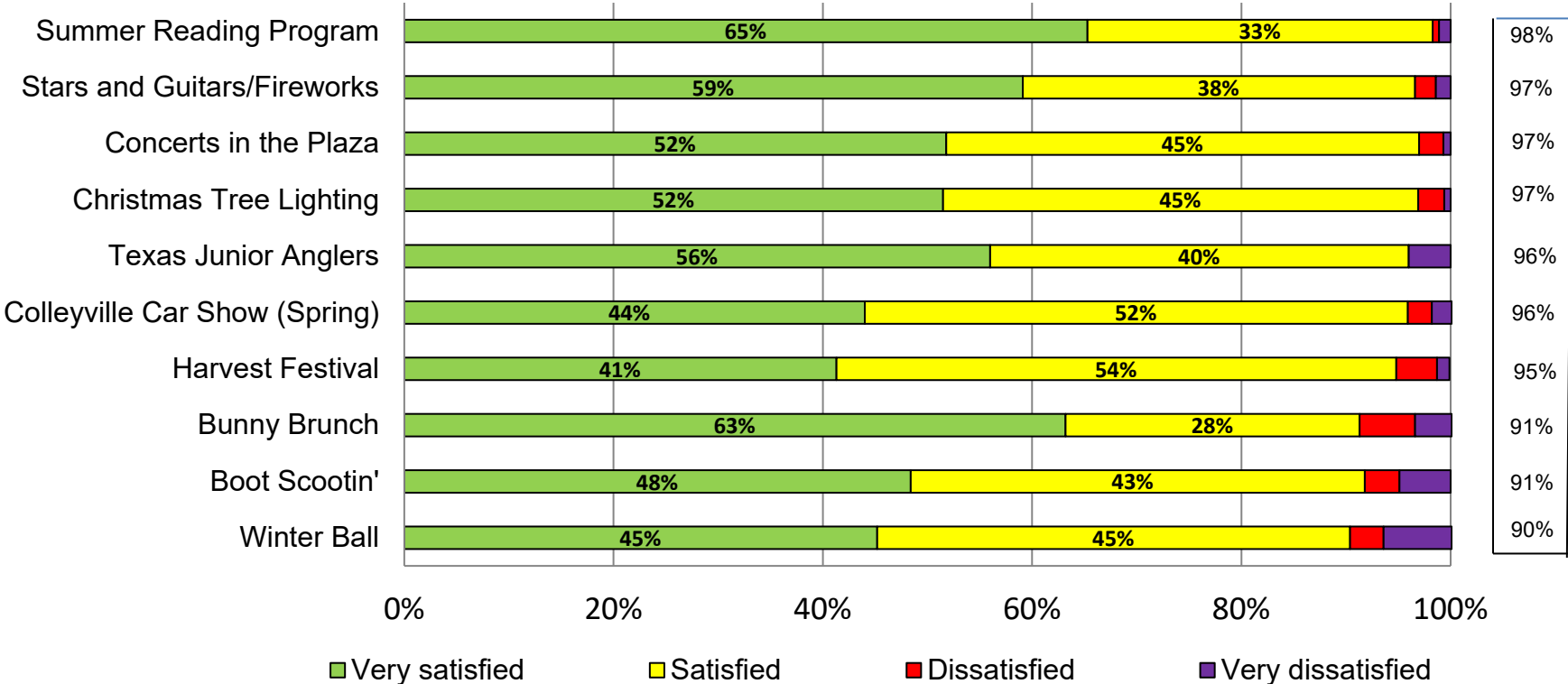

**Q10a. Have you visited the Colleyville Recreation Center
(opened Fall of 2024)?**

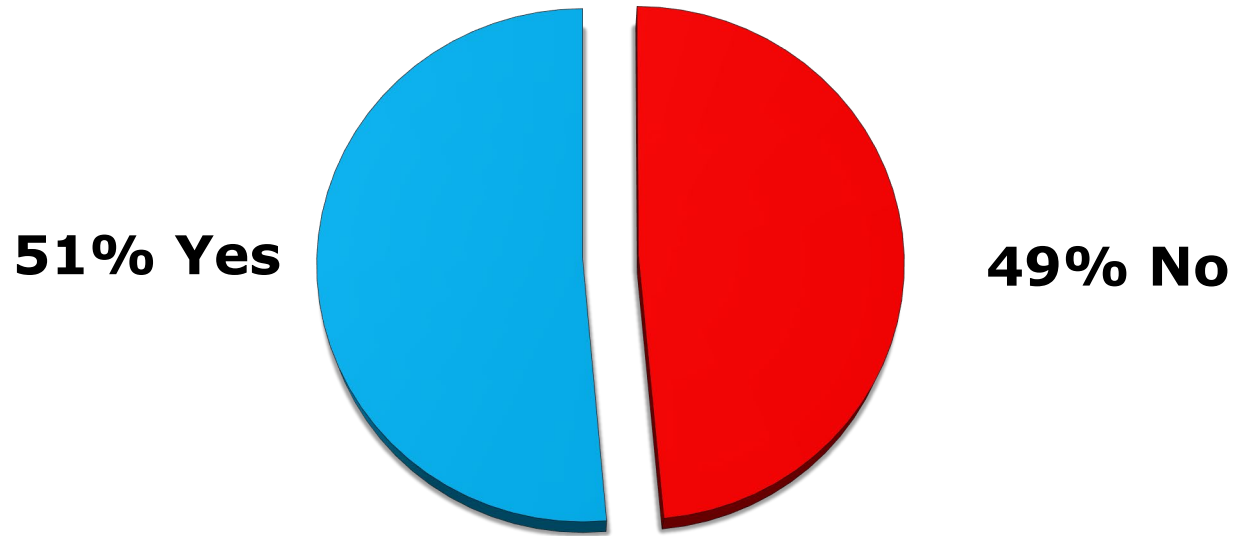

Q10b. What was your general impression of the facilities/programming at the Recreation Center?

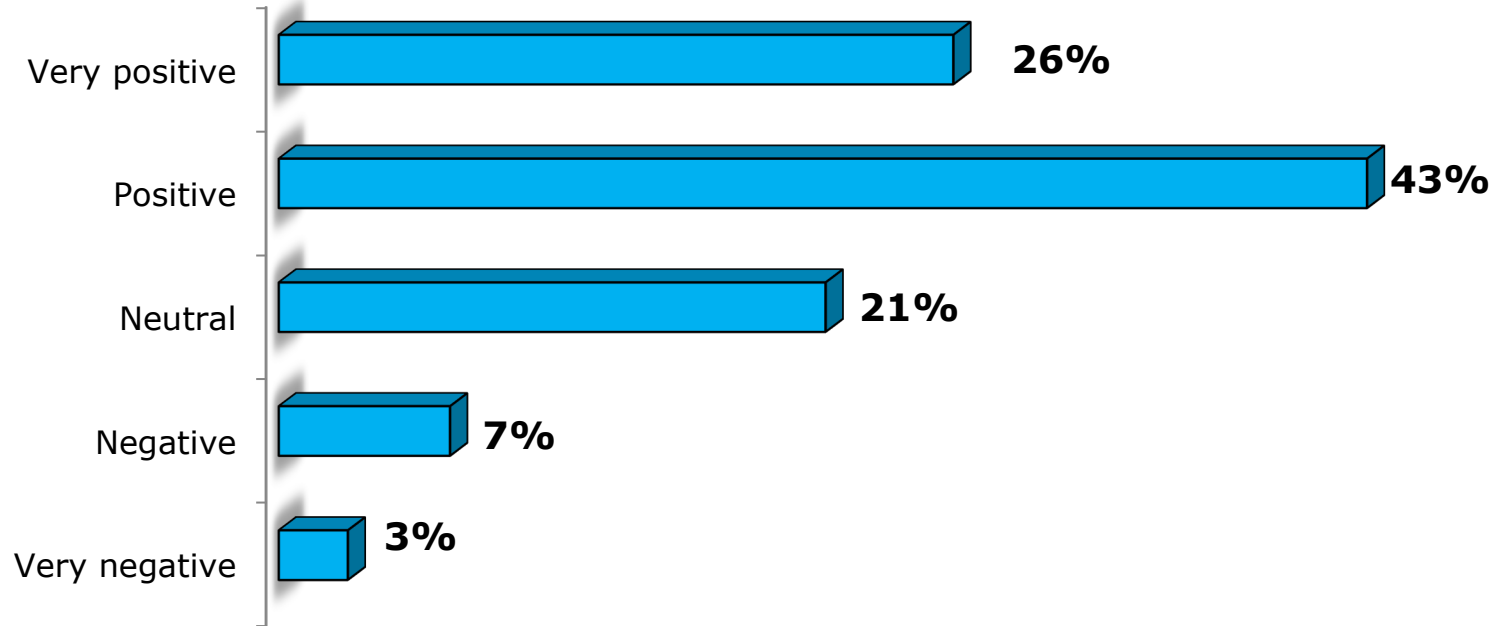

Q10c. What programs would you like to see at the Recreation Center? *(Check all that apply)*

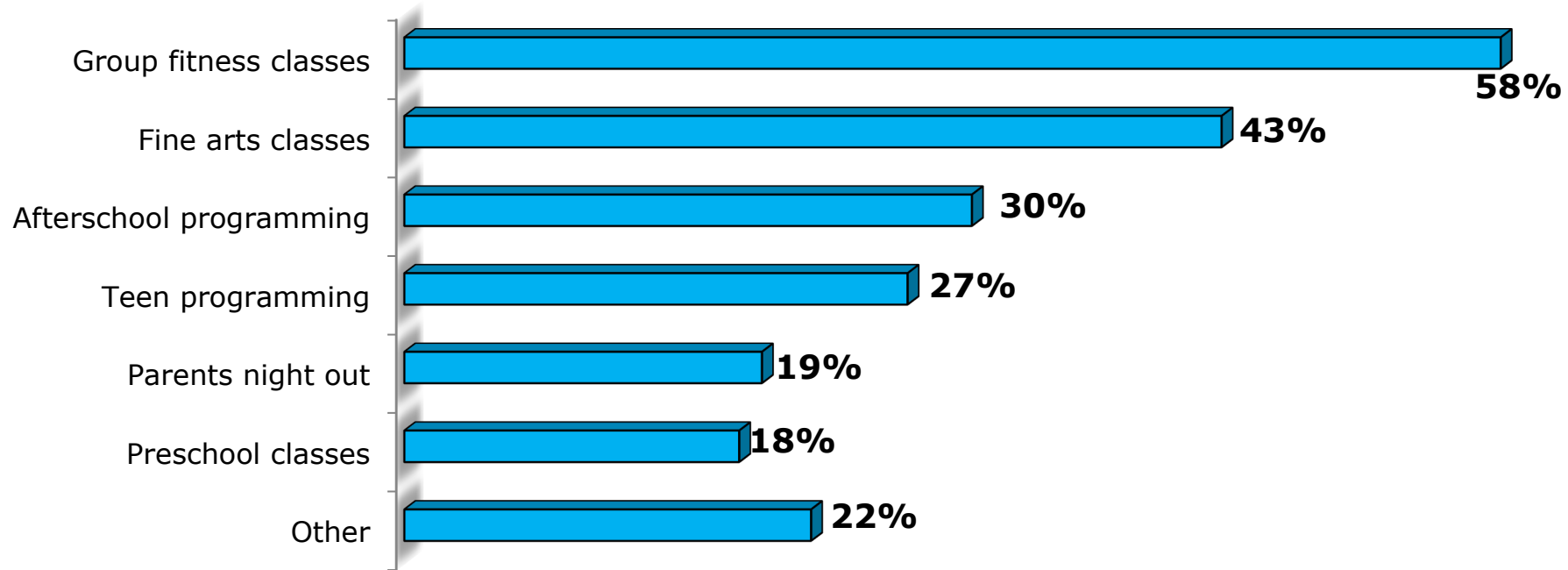

**Q11a. Have you visited the Colleyville Senior Center
(re-opened January of 2024)?**

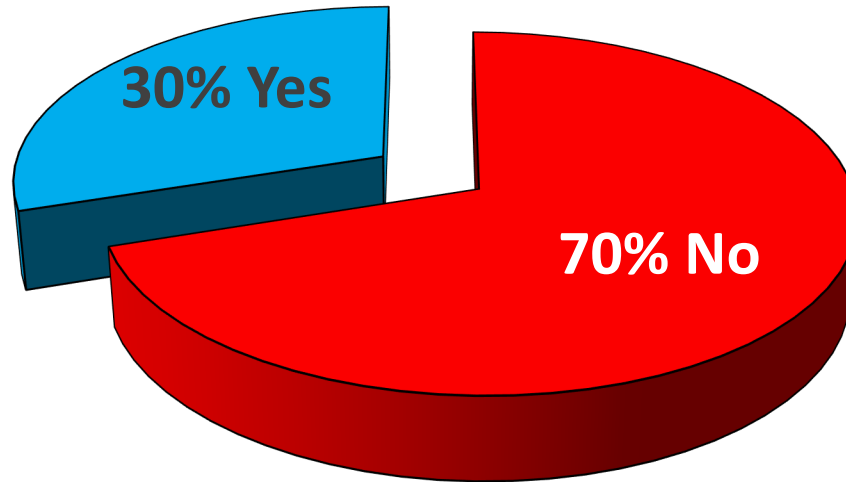

Q11b. What was your general impression of the facilities/programming at the Senior Center?

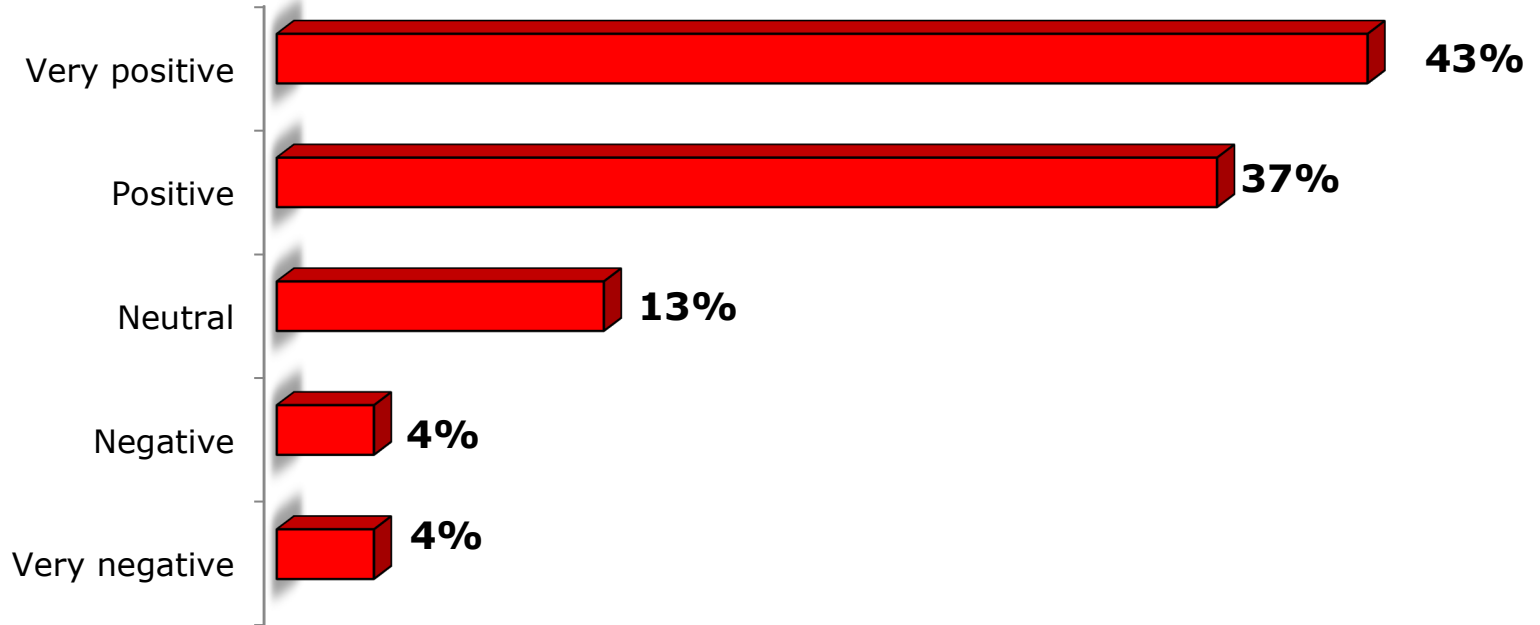

Recreation, Senior Center & Library Programs



Q11c. What programs would you like to see at the Senior Center? (Check all that apply)

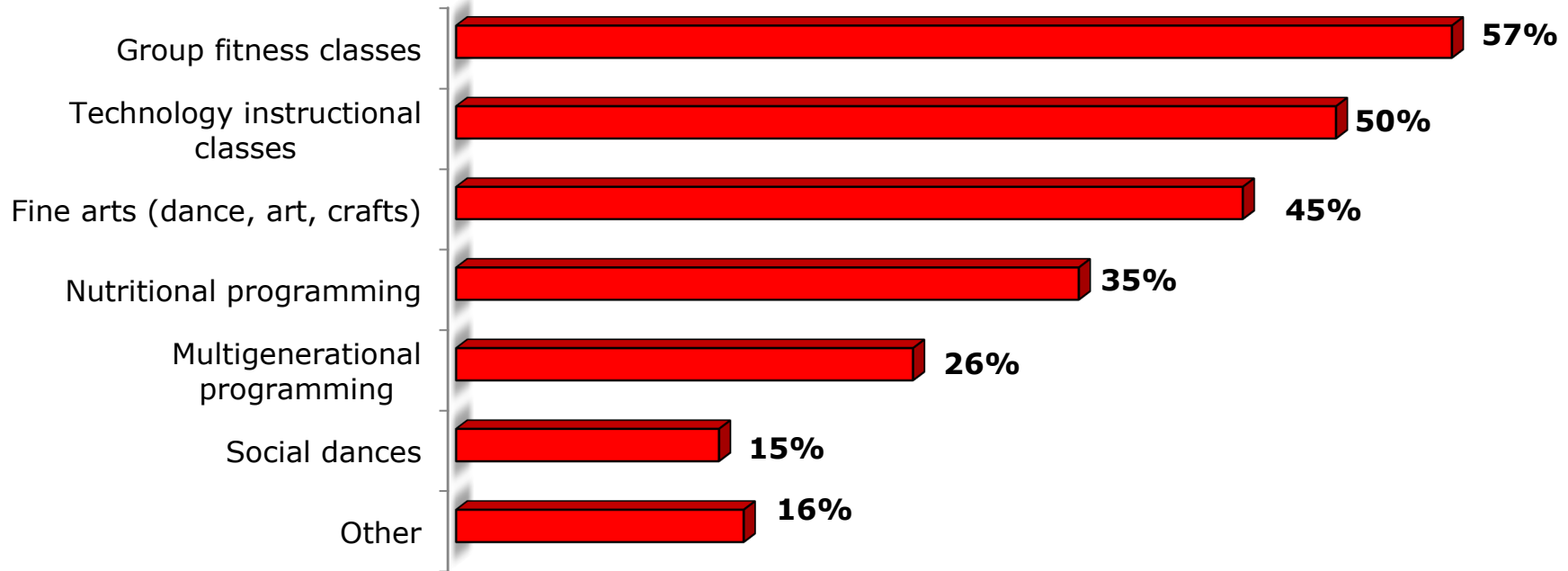

Q12a. Have you visited the Colleyville Library?

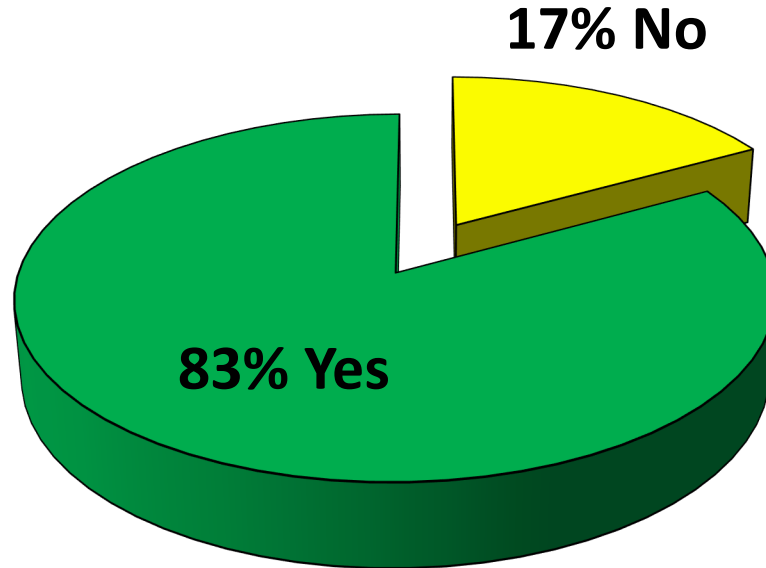

Q12b. What was your general impression of the facilities/programming at the Library?

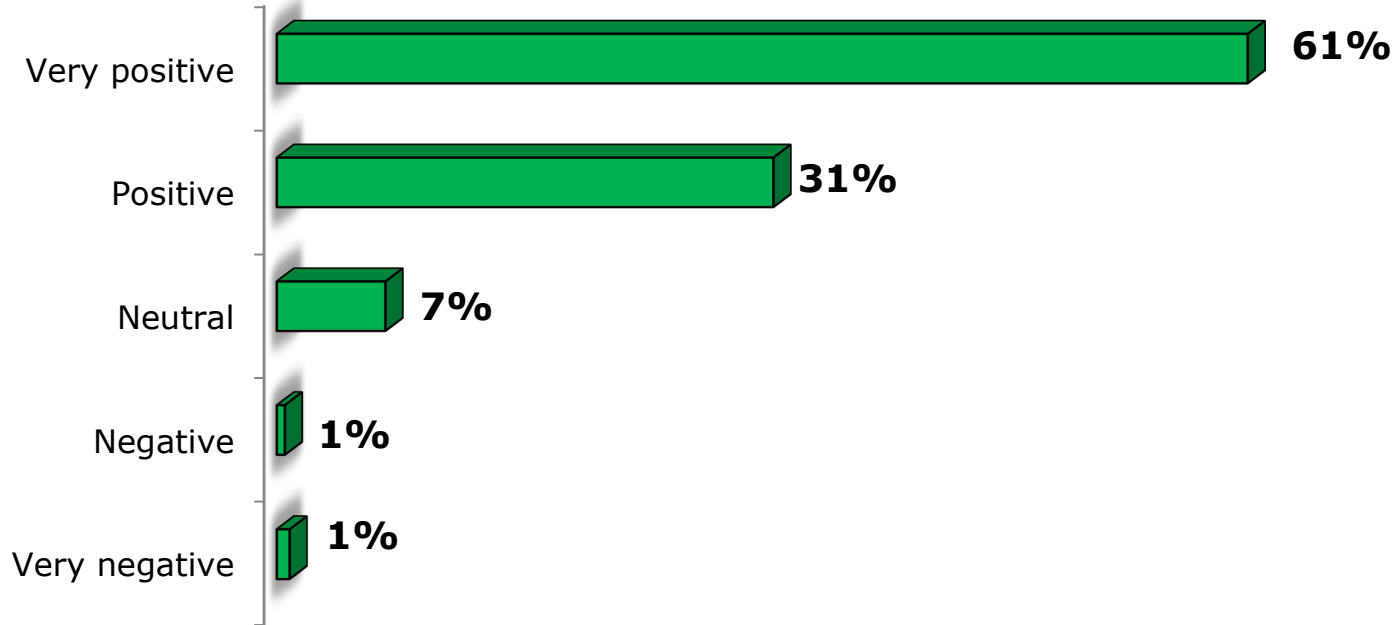

Recreation, Senior Center & Library Programs



Q12c. What programs would you like to see at the Library? *(Check all that apply)*

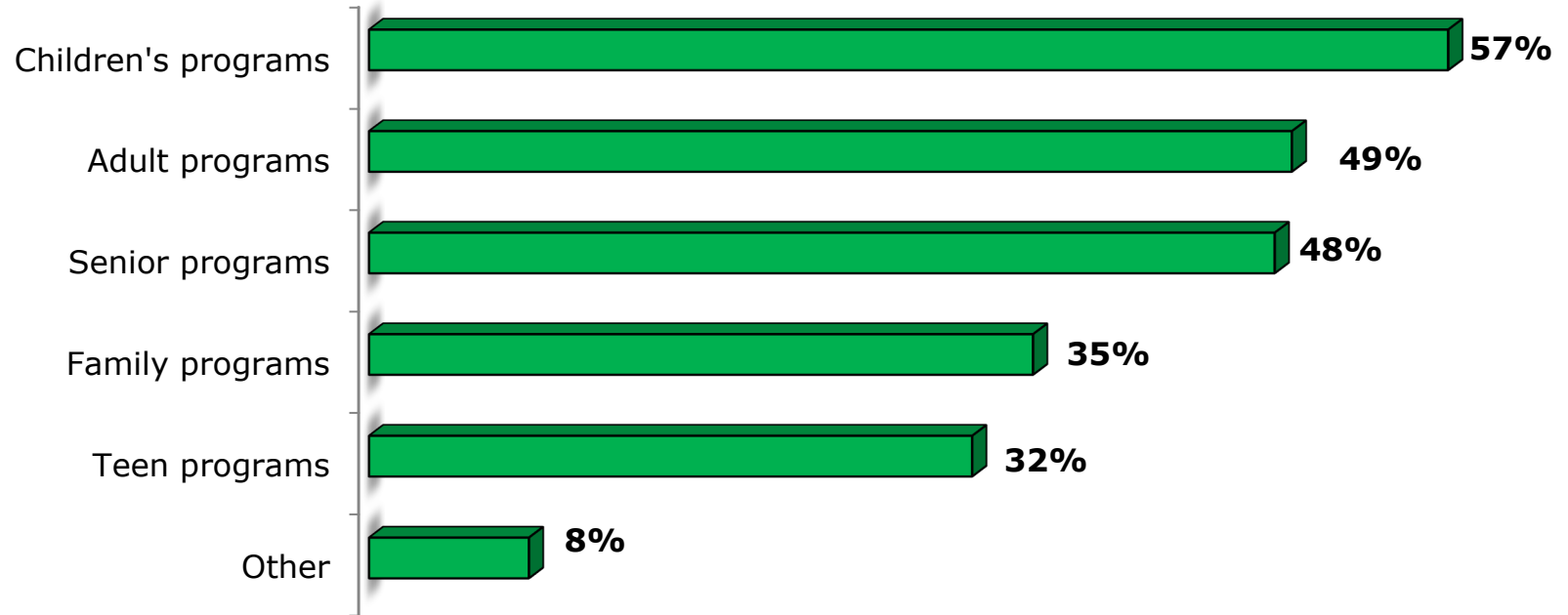

Q13a. In the last 12 months, how often have you visited these Colleyville Parks?

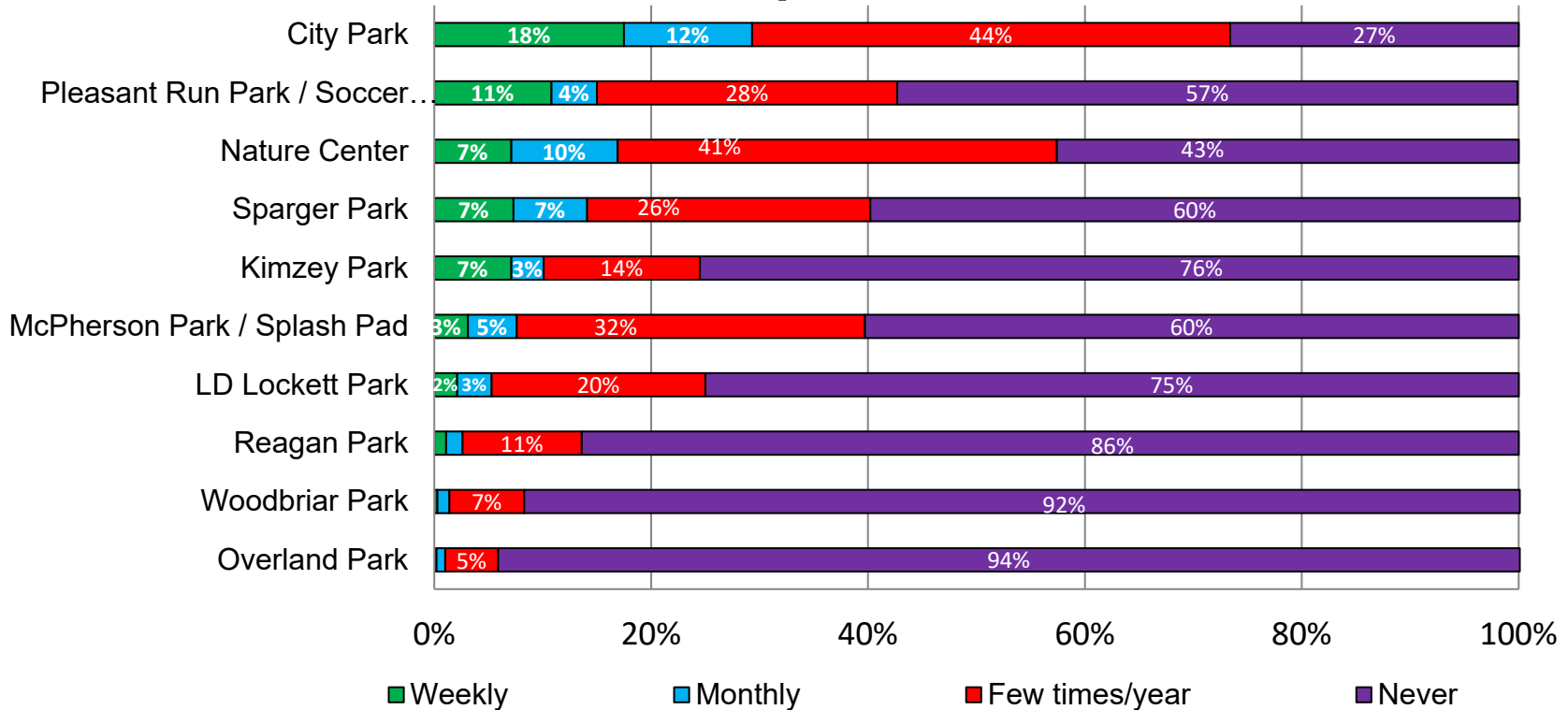

Q13b. Of the parks you have visited, what was your satisfaction level?

COMBINED PERCENTAGES: VERY SATISFIED/SATISFIED (Excludes "never visited" responses)



Demographics

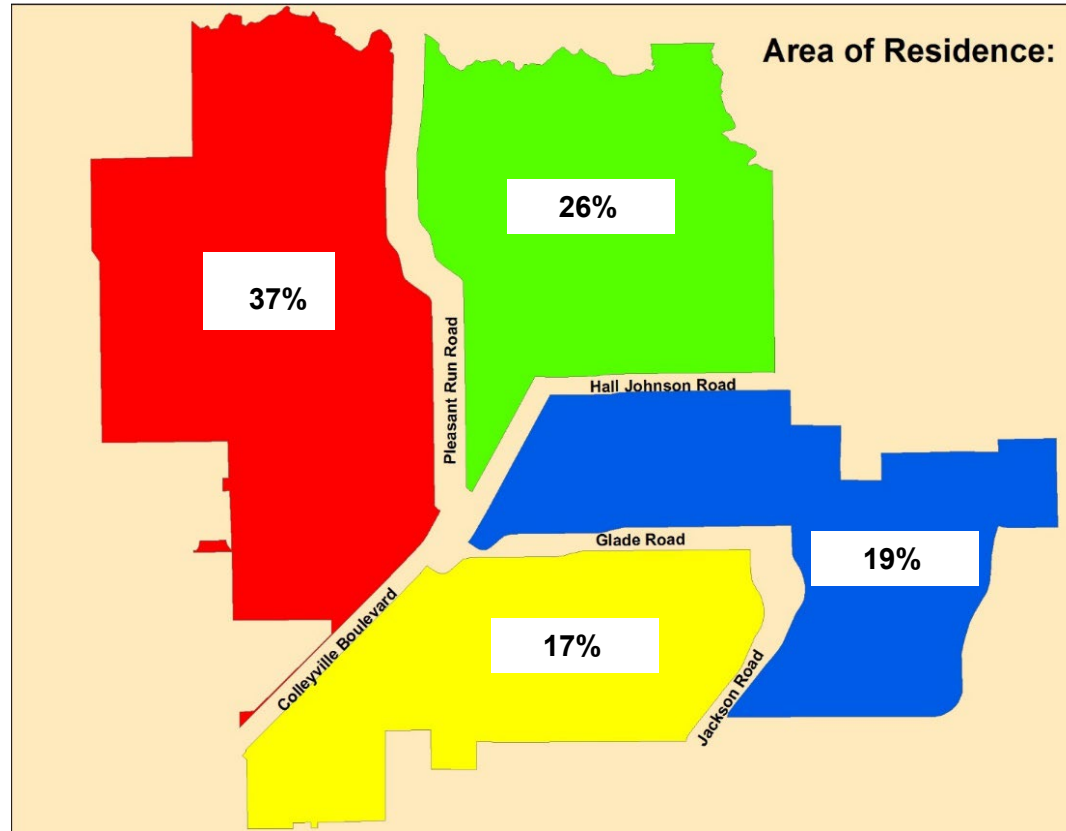

Demographics



Which of the following applies to the head of household?

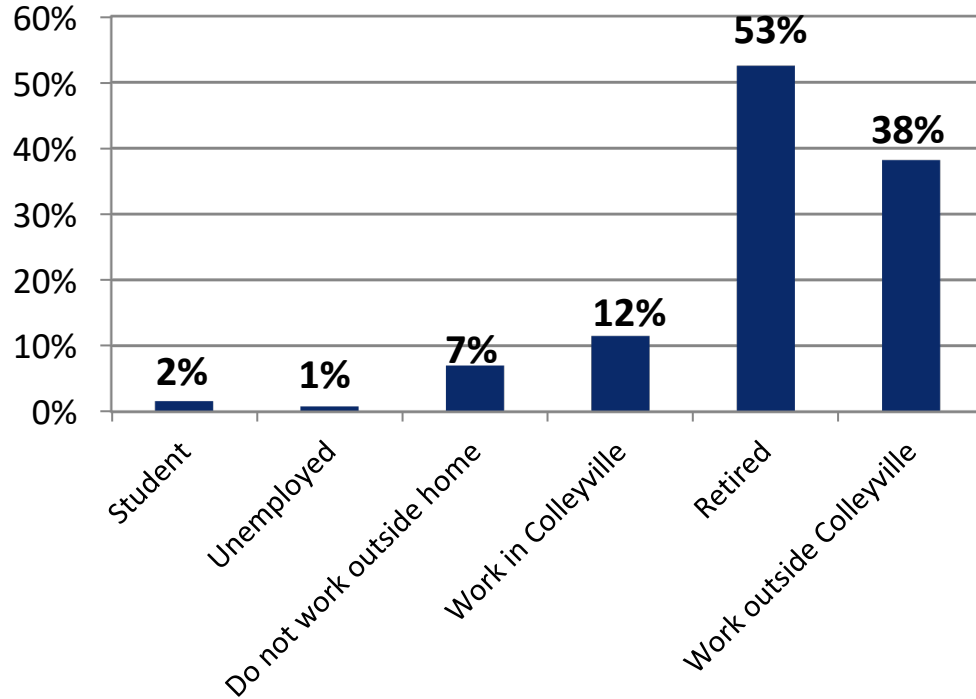

Gender

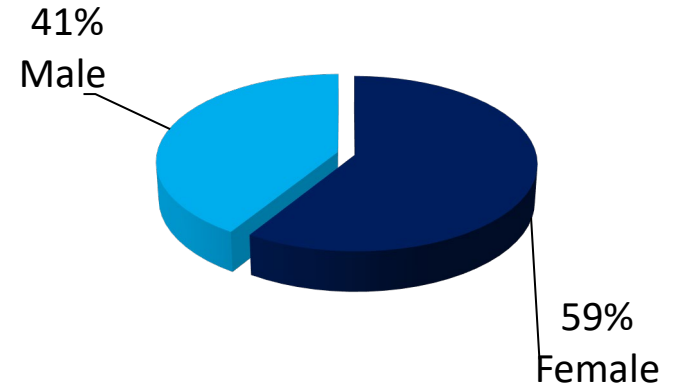

Your Age?

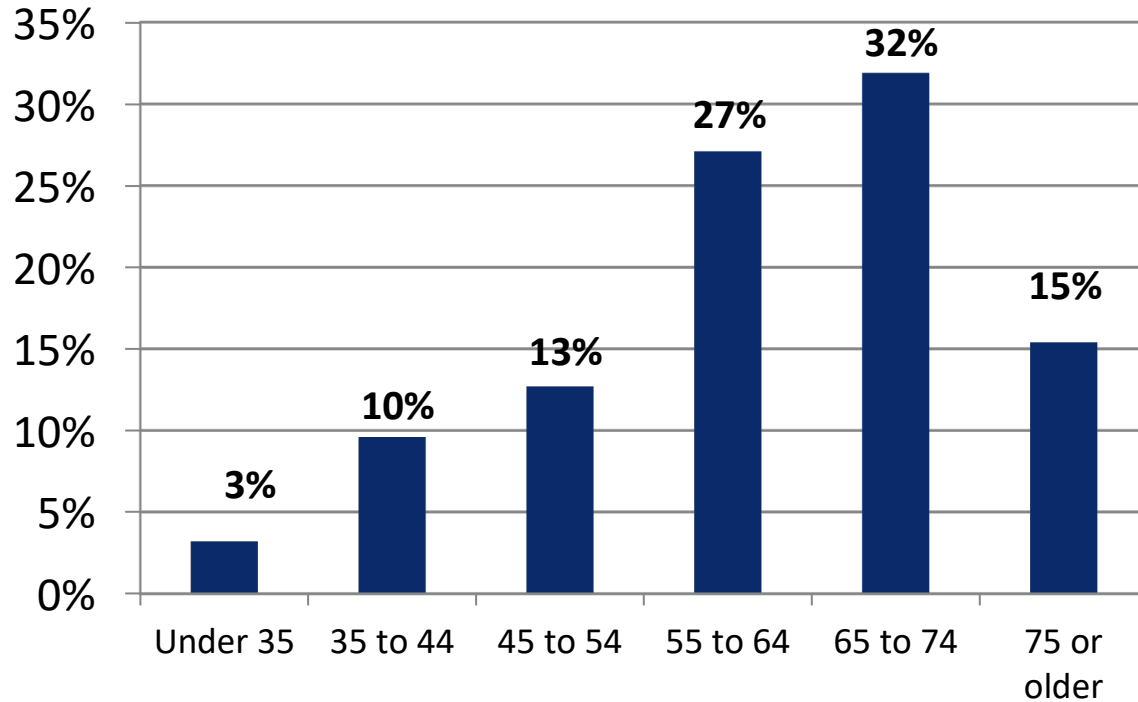

How long have you lived in Colleyville?

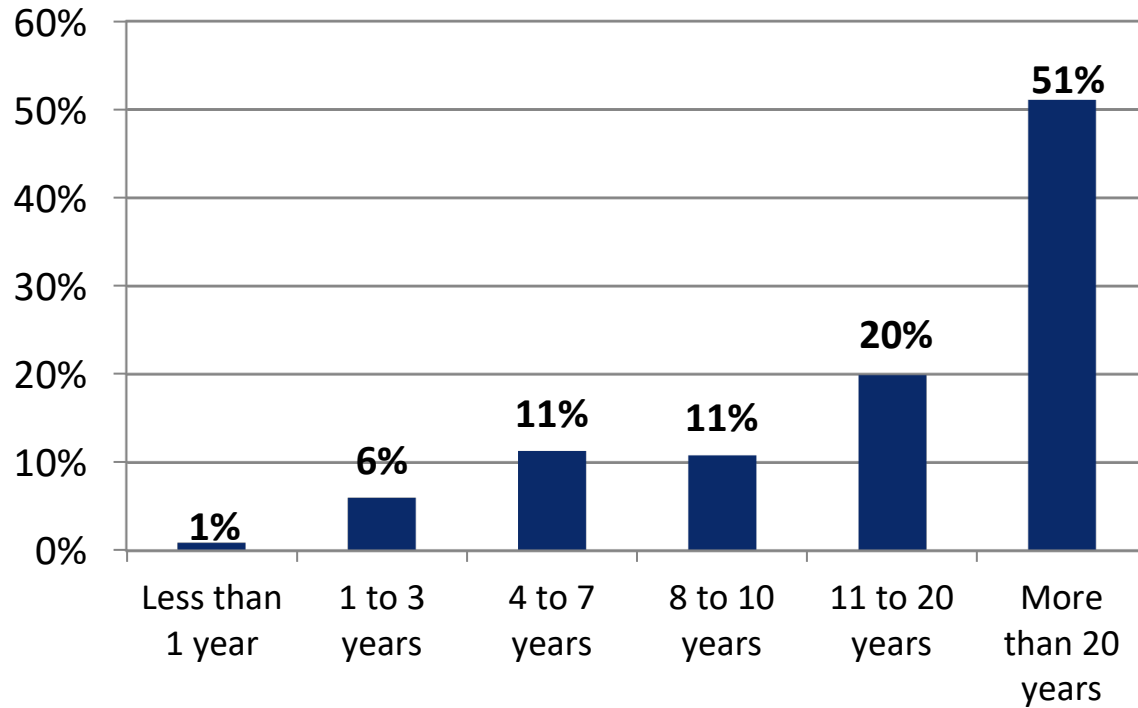

Demographics



Which youth age groups are represented in your household?

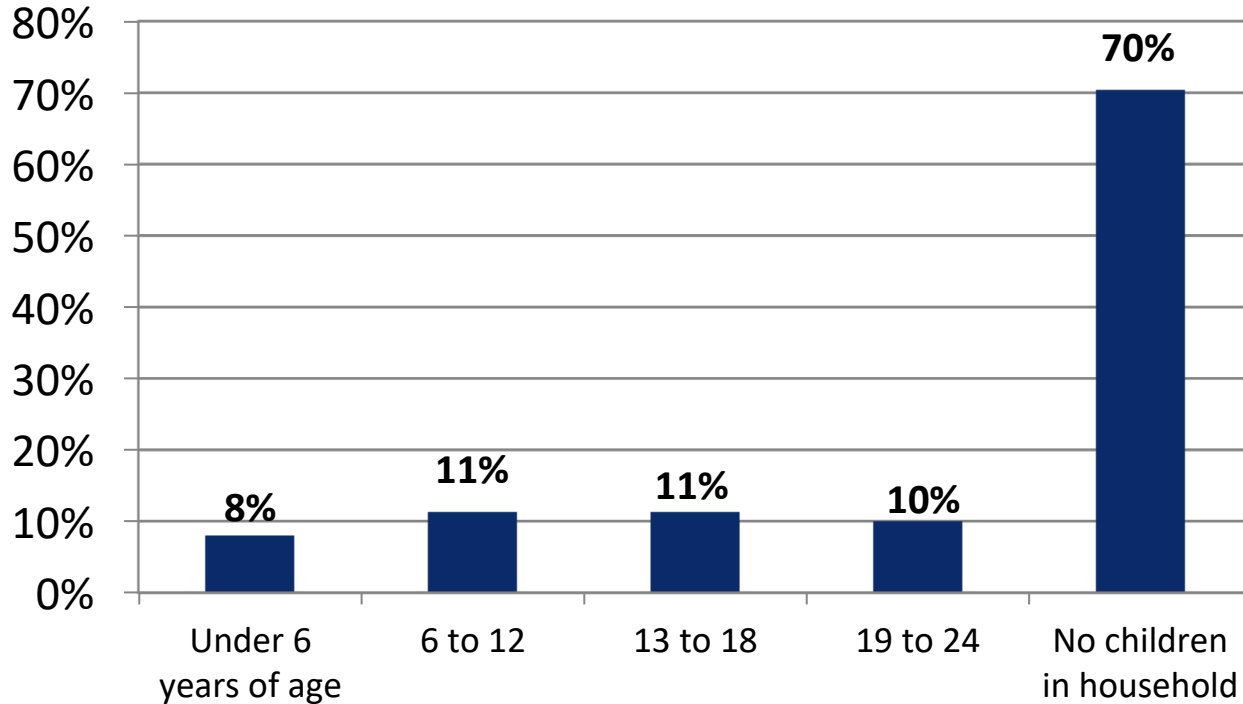

Responses will add to more than 100% due to multiple responses allowed

Demographics



Do you own or rent your home?

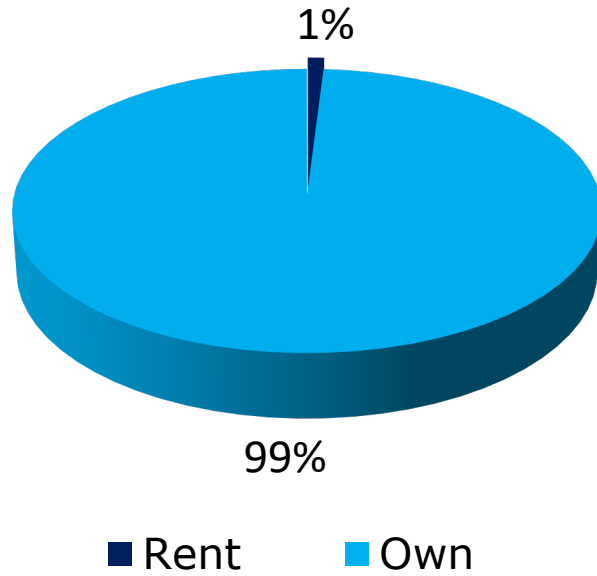

Do you have an older parent or relative living with you?

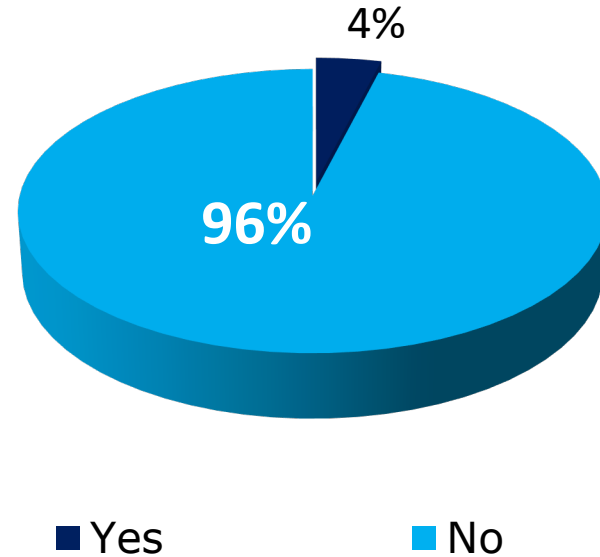

Questions?



CITY OF COLLEYVILLE CITY COUNCIL BRIEFING

Agenda Number WS-2

Agenda Date 12/16/2025

Type Worksession

Department Economic Development

Title

Economic Development Update

Explanation

City staff will provide an Economic Development update.

Attachments

1. Economic Development Update - December 2025



Colleyville Economic Development Update

Worksession
December 16, 2025



Strategy: Smart Growth with Style

Our economic development strategy is all about attracting, growing, and keeping a high-quality mix of businesses that not only serve our residents and visitors, but also complement the charm and beauty that make Colleyville special.

Behind every decision are key principles that guide our approach; balancing smart growth, aesthetic appeal, and community values.

Why Colleyville?

Colleyville is more than a great place to live. It's where businesses succeed and communities shine.

Whether you're investing, expanding, or just getting started, Colleyville offers a supportive, strategic, and stunning location.



2025 IMPACT

\$8,709

Brighten Up the Boulevard
Christmas Light Grant
2025



\$695,400

BEST Grant
Matching funds to date

\$41,000

Colleyville Gives
Grant 2025 so far
\$542,100 since 2018



\$156,512

SIGN Grant
Matching Funds to date



\$253,785

Economic Impact
Restaurant Only Gift Cards
2024: \$126,700
2025: \$127,085

\$50,000

SAFER Grant
Matching Funds to date

\$5,052,140

Economic Impact
Gift Cards from 2018



\$6,069,761.00

Economic Impact
Since 2018



93%

Occupancy Rate

Analytics

\$26.00/Sq Ft

Market Median Rent Rate

264K Sq Ft

Available Square Footage to lease

3.1M Sq Ft

Square Feet Inventory

20K Sq Ft

Under Construction

Colleyville!

2024 NICHÉ BEST PLACES

#1 BEST PLACE TO LIVE IN TARRANT COUNTY (DFW)

GRAPEVINE COLLEYVILLE INDEPENDENT SCHOOL DISTRICT

#2 Best DFW School District
#4 Best Texas School District

Award Winning Community

Police, Fire, Library, Parks and Recreation, Finance, Economic Development, Community Development, Public Works

OPEN for BUSINESS

City Grant Programs for Businesses
Gift Card Program for Residents
Promotional Programs for Local Businesses

26,057 People

9,395 Households

13.1 Square Miles

\$203,566 Median Household Income

46.3 Median Age

70.3% Hold Bachelors Degree or Beyond Highly Educated Population

LOVE Colleyville SH8P Colleyville



93%

Occupancy Rate

Analytics

\$26.00/Sq Ft

Market Median Rent Rate

264K Sq Ft

Available Square Footage to lease

3.1M Sq Ft

Square Feet Inventory

20K Sq Ft

Under Construction

Market Asking Rent & Asking Rent Per SF

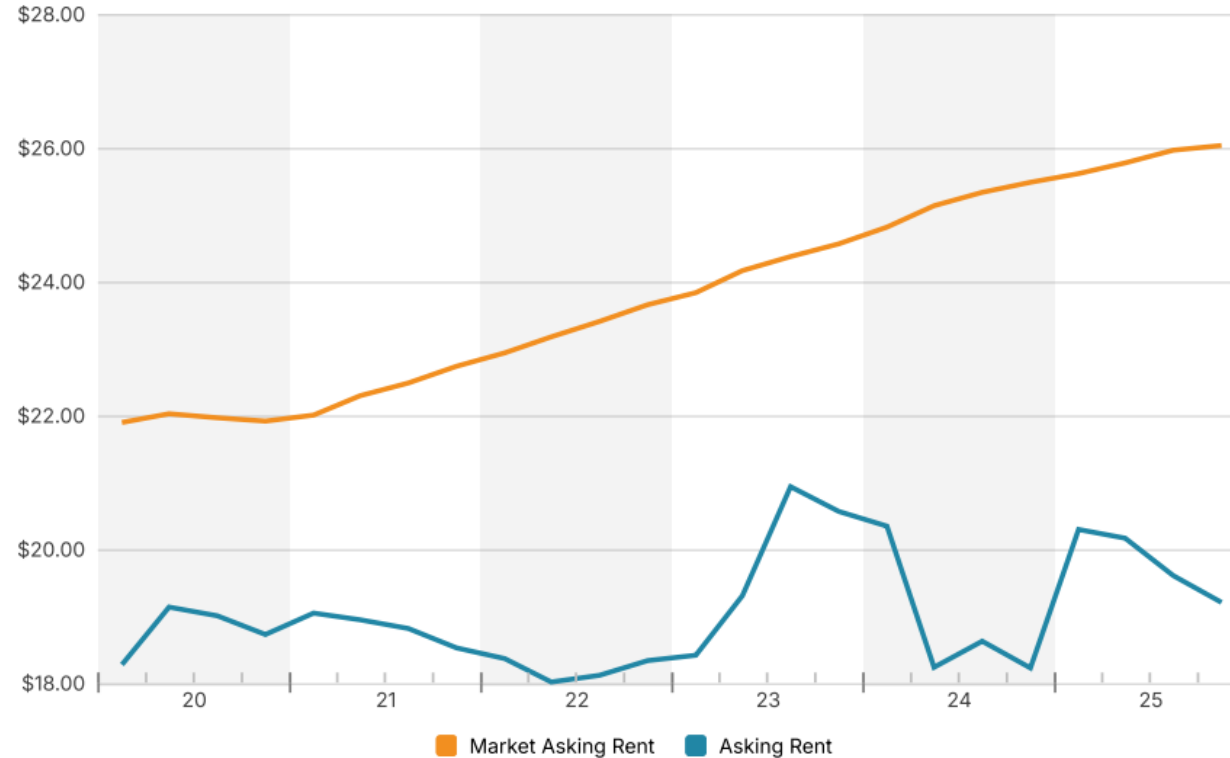

93%

Occupancy Rate

Analytics

\$26.00/Sq Ft

Market Median Rent Rate

264K Sq Ft

Available Square Footage to lease

3.1M Sq Ft

Square Feet Inventory

20K Sq Ft

Under Construction

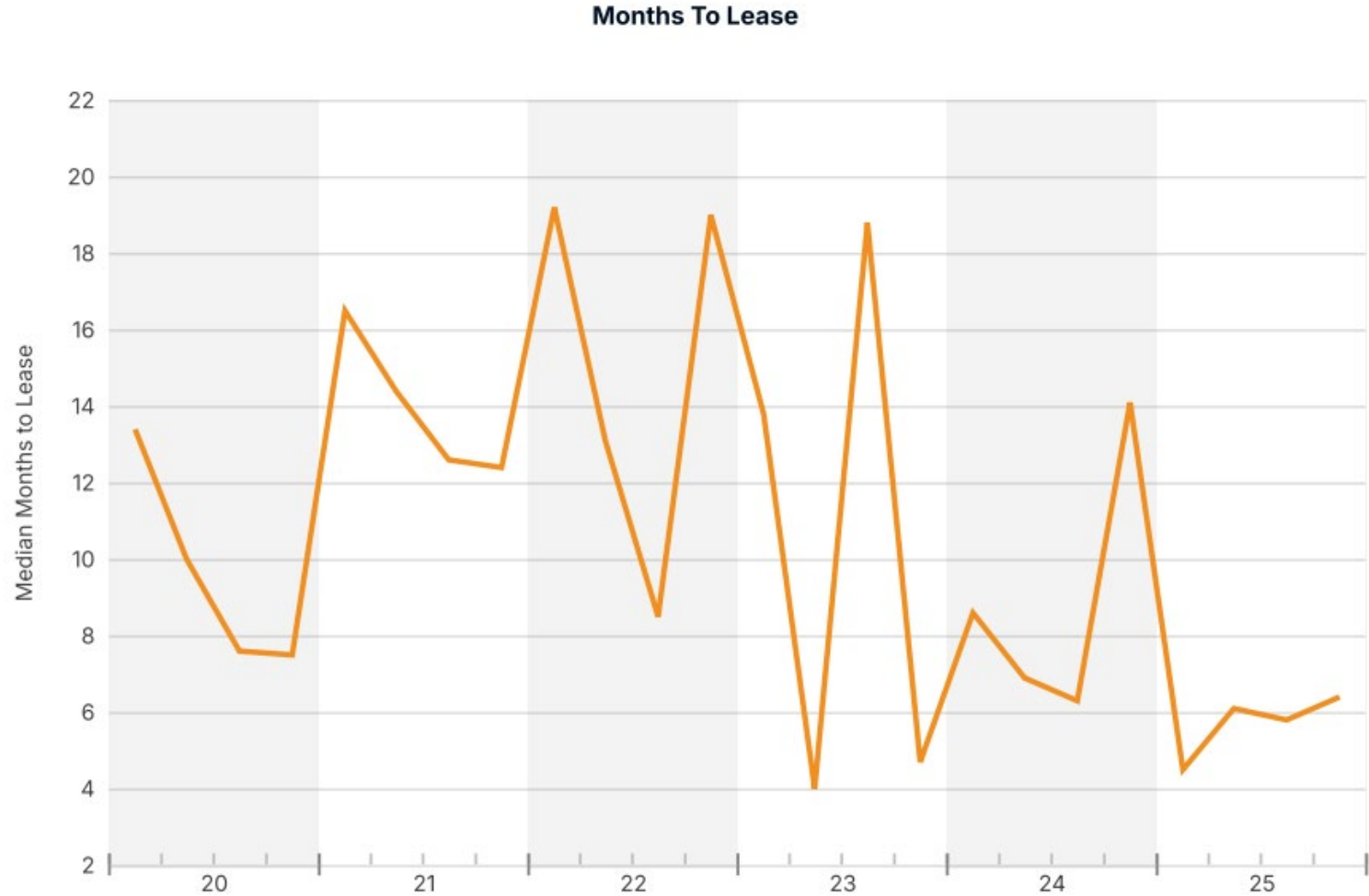

93%

Occupancy Rate

Analytics

\$26.00/Sq Ft

Market Median Rent Rate

264K Sq Ft

Available Square Footage to lease

3.1M Sq Ft

Square Feet Inventory

20K Sq Ft

Under Construction

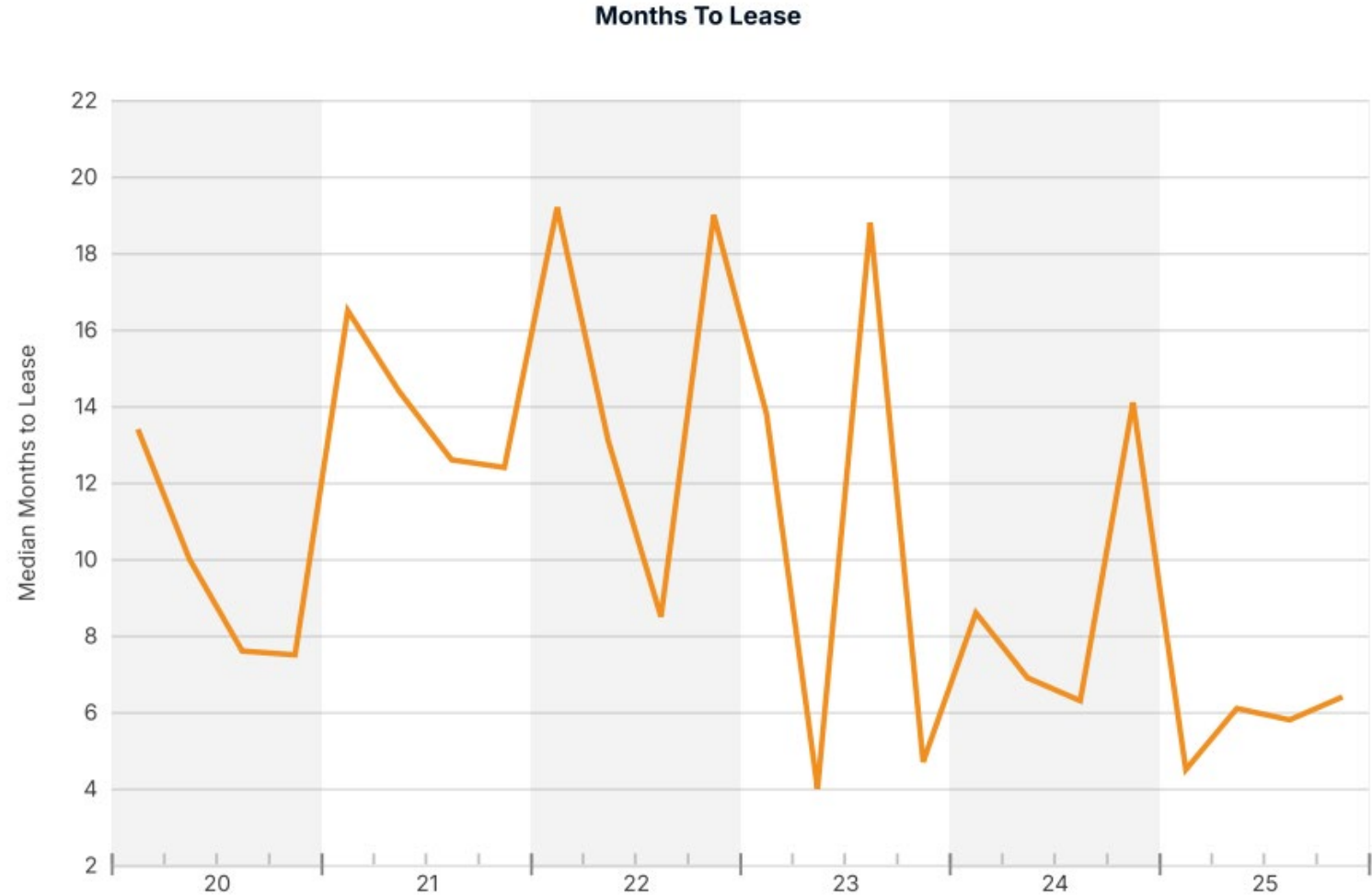

93%

Occupancy Rate

\$26.00/Sq Ft

Market Median Rent Rate

264K Sq Ft

Available Square Footage to lease

3.1M Sq Ft

Square Feet Inventory

20K Sq Ft

Under Construction

Analytics

The Village Colleyville Visits YOY

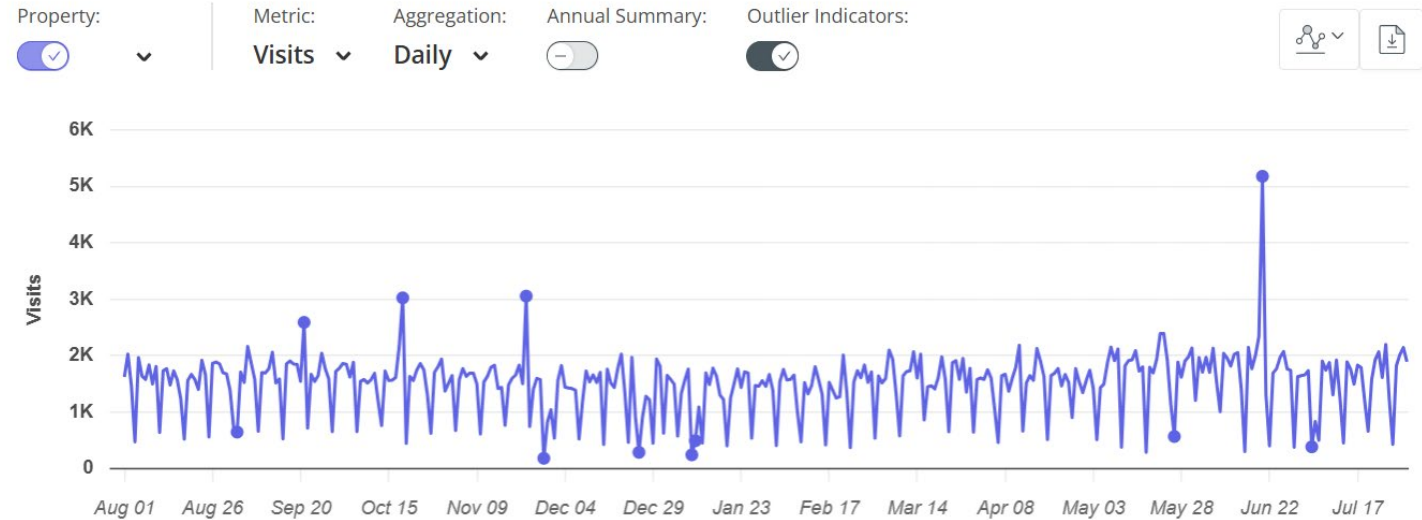

Visits	549.3K	Avg. Dwell Time	68 min
Visits / sq ft	0.17	Panel Visits	44.3K
Size - sq ft	3.1M	Visits YoY	+1.3%
Visitors	147.9K	Visits Yo2Y	+4.1%
Visit Frequency	3.71	Visits Yo3Y	+16.8%



93%

Occupancy Rate

Analytics

\$26.00/Sq Ft

Market Median Rent Rate

264K Sq Ft

Available Square Footage to lease

3.1M Sq Ft

Square Feet Inventory

20K Sq Ft

Under Construction

The Village Colleyville
63% Occupancy in early 2025
81% Occupancy in December 2025

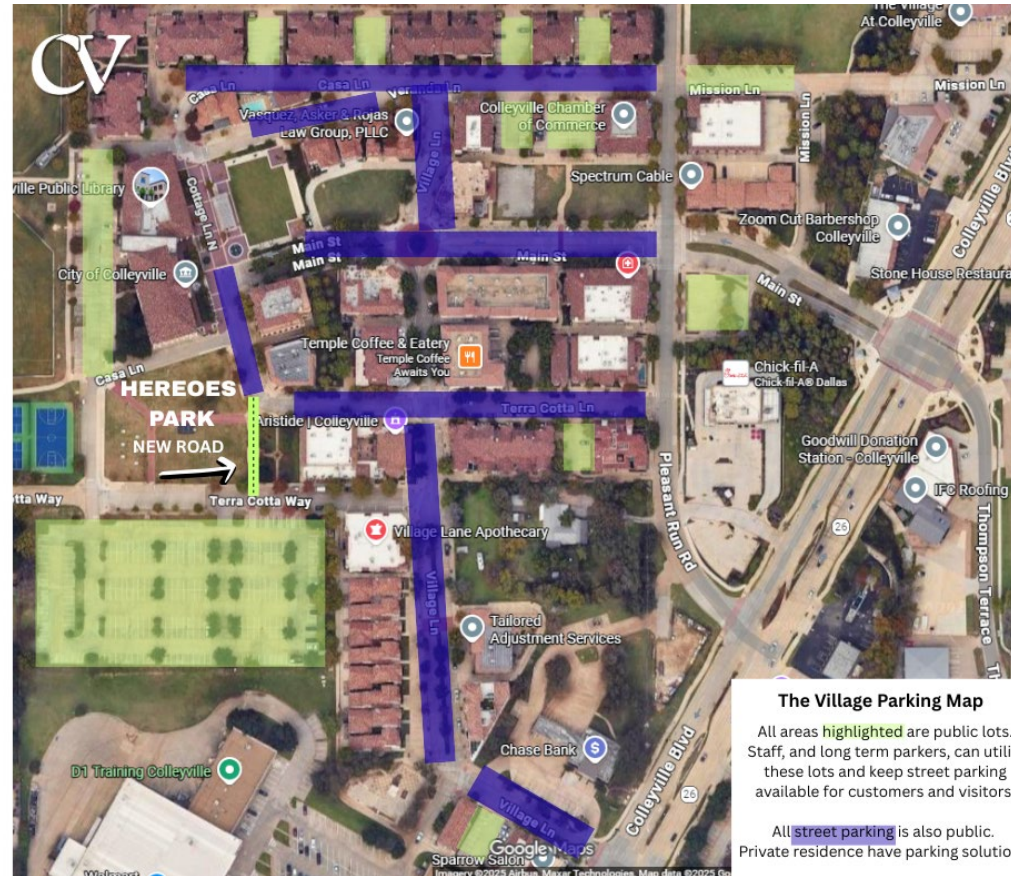

93%

Occupancy Rate

Analytics

\$26.00/Sq Ft

Market Median Rent Rate

264K Sq Ft

Available Square Footage to lease

3.1M Sq Ft

Square Feet Inventory

20K Sq Ft

Under Construction

Center	Dwell Time	Visitors	YoY
Town Center Colleyville	39 min	193k	-6%
Glade Points	25 min	100k	+7%
Walmart	22 min	60k	+1%
Tara Village	31 min	18k	+5%
Colleyville Downs	37 min	152k	-0.5%
The Village	22 min	50k	+5%



Sales Tax Collections 2020-2025



NEEDS UPDATE

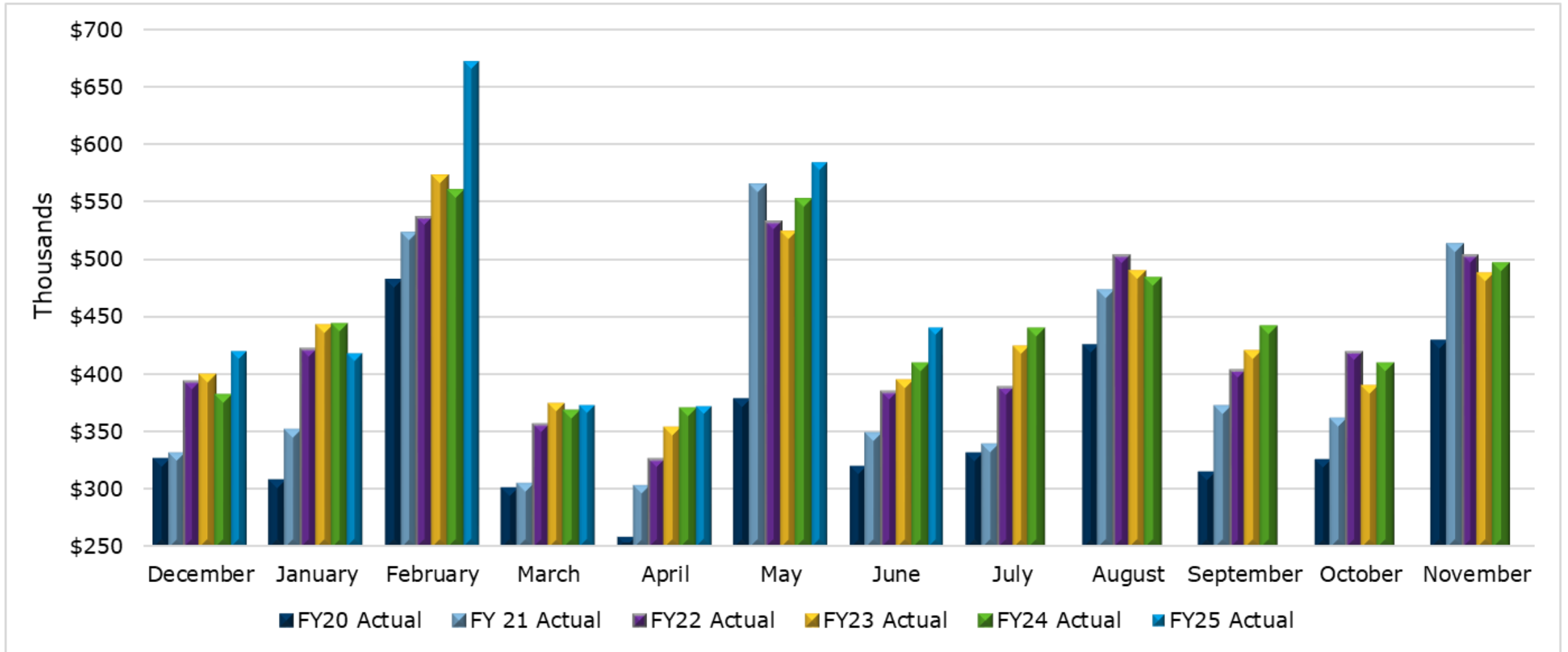

GRANT: Brighten Up the Boulevard

Grant: BEST

Grant: Neighborhood Entrance Beautification

Grant: SAFER

Grant: SIGN

Helpful Links

Incentives

Property & Development Opportunities

Resources

Restaurant Roadmap 2024

Supporting Our Businesses

Supporting Businesses. Strengthening Community.

The **Colleyville Economic Development team** is here to champion the business community by supporting existing businesses, welcoming new ones, and ensuring both residents and entrepreneurs have what they need to thrive right here in Colleyville.

[Click here for the latest Economic Development Update 10/29/25](#)

Our Strategy: Smart Growth with Style

Our economic development strategy is all about attracting, growing, and keeping a high-quality mix of businesses that not only serve our residents and visitors, but also complement the charm and beauty that make Colleyville special.

Behind every decision are key principles that guide our approach; balancing smart growth, aesthetic appeal, and community values.

Why Colleyville?

Colleyville is more than a great place to live. It's where businesses succeed and communities shine. Whether you're investing, expanding, or just getting started, Colleyville offers a supportive, strategic, and stunning location.

[Check out our one-pager to see why Colleyville works for YOU.](#)

Economic Development Goals & Objectives

RESOURCES

[Business Directory](#)

[Beautification Guidelines](#)

[Business Information Guide](#)

[Business Mentor-SCORE](#)

[New Business Navigator](#)

[Permit Applications](#)

[Seasonal Programs](#)

[Gift Cards](#)
[Engagement](#)

Local Groups

[Colleyville Chamber of Commerce](#)

[Colleyville Executive Organization](#)

[Colleyville Lion's Club](#)

[Colleyville Woman's Club](#)

[Northeast Leadership Forum](#)

[Rotary Club of Colleyville](#)





LOVE SHOP
Colleyville? Colleyville!



COMMUNITY BUSINESS GUIDE



Colleyville Commercial Bus Tour



COLLEYVILLE
COMMERCIAL
BUS TOUR MAP

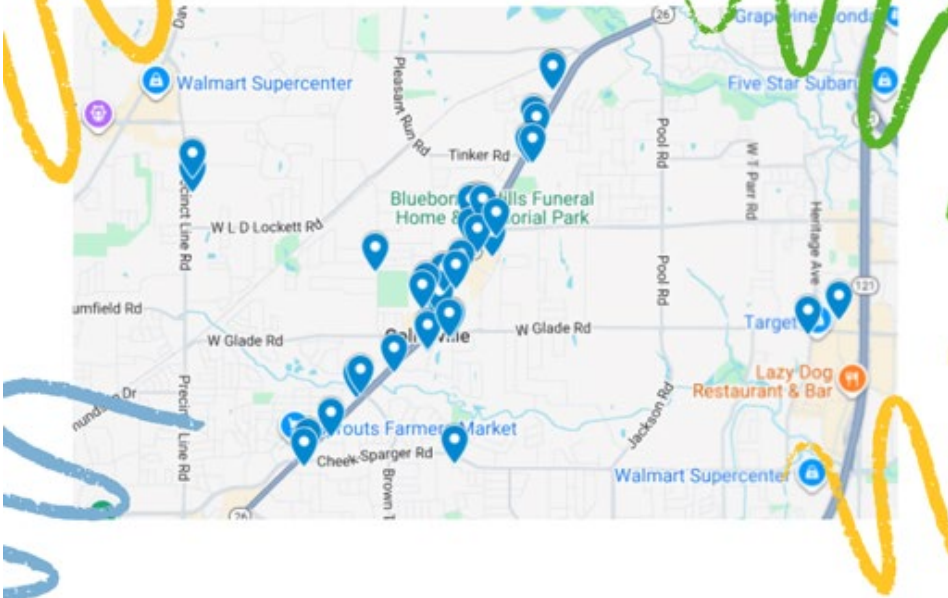



STEP 1: SET UP BUSINESS

- Incorporate New Business**
Must file with the Texas Secretary of State office.
sos.state.tx.us | 512-463-5555
- Obtain Employer Identification Number (EIN)**
All employers who have employees must be assigned an EIN from the United States Internal Revenue Service (Form SS-4). [IRS.gov/ein](https://irs.gov/ein)
- Obtain Business Name/DBA**
This establishes the sales tax collection process with the State of Texas.
Tarrant County Clerk 817-884-1195
TarrantCountyTX.gov
- Obtain Lease from Landlord**
Lease terms should be negotiated prior to application for Certificate of Occupancy (CO).
- Write a Business Plan**
A business plan outlines how the business intends to grow and sustain revenues and is required for obtaining a Certificate of Occupancy (CO) from the City. <https://shorturl.at/amoYk>
- Texas Sales & Use Tax Permit**
A Sales Tax Permit is required if selling taxable services or selling/leasing personal property and is required for obtaining a Certificate of Occupancy (CO) from the City.
comptroller.texas.gov/taxes/permit

STEP 2: PREPARE THE SPACE

- Confirm Business Use Zoning and/or Special Use Permit requirements**
Review the Zoning Map and the Land Development Code at <https://shorturl.at/RAmyF>.
- Submit Application for Construction Permits/ Tenant Improvements**
Prior to any construction, demo, alteration, or improvement, review Community Development webpage to determine permits required and apply.
- Submit Application for Fire Protection**
Depending on building use, occupant load, or other factors, additional life-safety systems may be required. Must receive approval before application of Certificate of Occupancy.

STEP 3: PREPARE TO OPEN

- Apply for a Certificate of Occupancy**
Apply online at <https://shorturl.at/tCObV>.
- Apply for a Food Service Permit**
Tarrant County Operator 817-884-1111
TarrantCountyTX.gov
- Apply for TABC license, for businesses selling or serving alcohol**
tabc.state.tx.us | 817-652-5912
The sale of alcoholic beverages is under the requisition of the state's Texas Alcoholic Beverages Commission (TABC).
- Submit Application for Sign Permit**
A permit is required prior to installation of any signs, including temporary signs, in accordance with Ch. 7 of Land Development Code.

STEP 4: SET UP SERVICES

- Apply for water service**
Utility Billing Customer Service 817-503-1020
<https://shorturl.at/qCdDh>.
- Apply for gas service**
Gas service is provided by Atmos Energy.
AtmosEnergy.com.
- Choose an electrical provider**
Learn more at PowerToChoose.org.
- Apply for mail service**
USPS will require a copy of the Certificate of Occupancy in order to begin mail service at your new address.
usps.com | 800-275-8777

STEP 5: CITY PROGRAMS & GRANTS

- Review City Grants** <https://shorturl.at/sgSV1>.
- Participate in Gift Card Program**
<https://shorturl.at/JV9uN>.
- Support Colleyville non-profit groups**
<https://shorturl.at/2WHeW>.

Business Information Guide

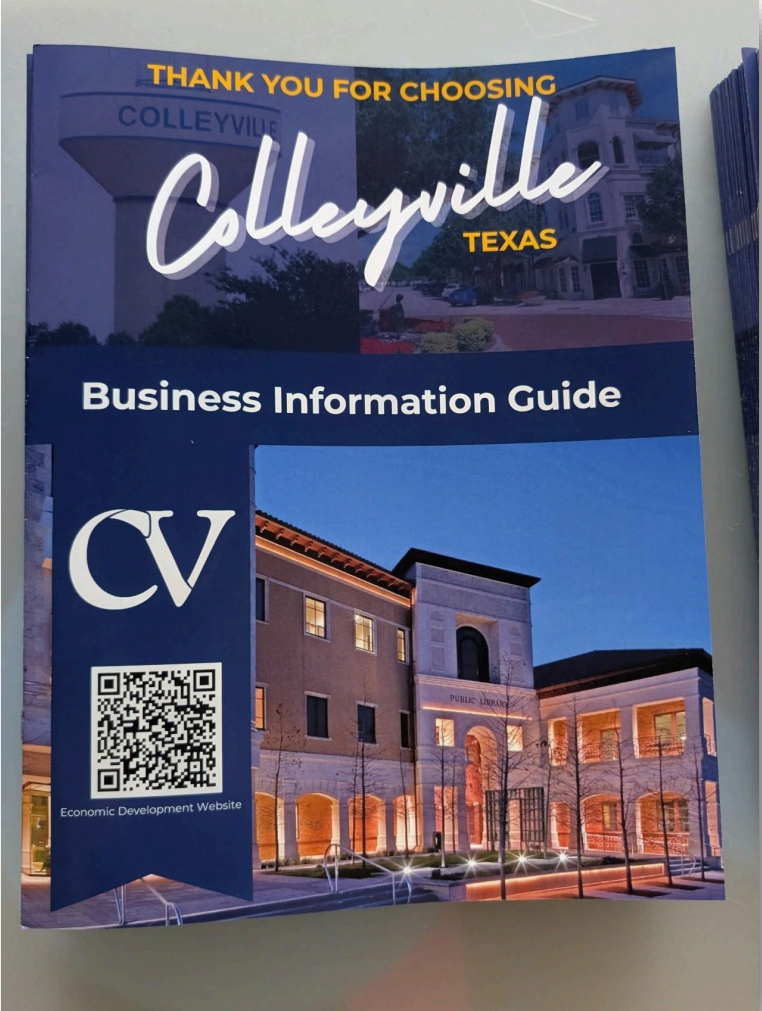

LOVE COLLEYVILLE? SHOP COLLEYVILLE BUSINESS BINGO

Put your money where your heart is!
Shop (5) in a row to receive (1) Colleyville Gift Card
Shop all squares and receive (2) Gift Cards

Dates and details on reverse side

RETAIL	DESSERT	BEVERAGE	GROCERY
BEVERAGE	SERVICE	GROCERY	HEALTH
PET	RETAIL	DINING	DESSERT
HEALTH	GROCERY	RETAIL	DINING
SERVICE	RETAIL	SERVICE	DINING



Support businesses five across, vertical, diagonal or complete the full board!

BINGO cards available at the Colleyville Center Monday, Nov. 24, 2025 through Friday, Jan. 9, 2026. All Gift Cards are valid through Sunday, Jan. 11, 2026.

Turn in BINGO card for Colleyville Gift Card(s) **Christmas 2025 version only**, beginning Mon, Dec 15 through Fri, Jan 9th, 2026.
Receipts dates Nov 24th-Jan 9th will be accepted.

*Receipts from each Colleyville business for each square are required.
5 different receipts for (1) Gift Card
25 different receipts for (2) Gift Cards*

Retail = boutique, hardware, clothing, gift, home decor, pharmacy, floral, etc.
Dining = full service, fast-food, or fast-casual restaurants.

Beverage = restaurant specializing in beverages.
Dessert = restaurant specializing in dessert goods.

Health = business specializing in health, fitness, pharmacy related products / services.

Pet = medical, grooming, retail, food products or services for pets.

Grocery = retail focused on food, household and/or pharmacy.

Service = automotive, consulting, construction, medical, landscaping, professional, etc.



➤ **\$41,000 approved 2025 thus far**



Brighten Up the Boulevard



➤ **\$8,709 approved 2025**

➤ **\$50,000 allotted for use**

Brighten up the Boulevard

Christmas Light Matching Grant



The City of Colleyville is offering a new Christmas Light Matching Grant for businesses along Colleyville Boulevard (SH26).

As part of the City's ongoing beautification efforts, this program provides partial funding to help businesses add festive holiday lighting. Let's work together to make SH26 shine bright this season!



For businesses along Colleyville Blvd (SH26)



Warm, white lights Focus on rooflines and building outlines
Wrapped trees may be eligible



50% Match!
Shopping Centers up to \$5,000
Individual Businesses up to \$2,000



1. Apply City
2. Approval
3. Install
4. Verification
5. Grant Reimbursement



2026 COLLEYVILLE *Receipt Race*

Help your school **WIN \$5,000**
by shopping in Colleyville!

The City of Colleyville and GCISD have partnered together
for a receipt race to support Colleyville businesses and GCISD schools!

How to play:

Shop anywhere in Colleyville **February 1st - March 31st**
and turn your receipts into your school's PTA
as you do for Box Tops. It's that easy!

All GCISD schools can participate.

Receipts are due to Colleyville City Hall by April 10th, 2026.

Grand Prize



The school that collects the most receipts of any value will
receive a prize donation to that school's PTA.

*All participating schools will receive a \$500 donation.



For more information, visit
Colleyville.com or call **817.503.1328**



NOW OPEN!!



*Birdie
Bridal*



Bank OZK



COLLEYVILLE
FLORIST
Your Community Flower Shop

COMING SOON



ever/body

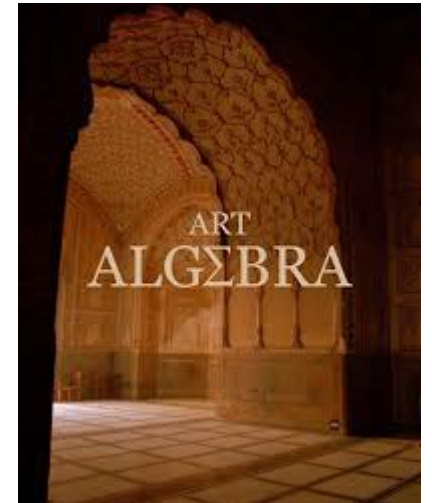

PROSPECTS



7 Brew
Ace Pickleball Club
Activate Games
Aunti Anne's
Barburrito
Big Chicken
Biscuit Bar
Blaze Pizza
Blue Bottle Coffee
Boot Barn
Boutique La Vie en Rose
Brew Culture
Brinker Intntl
Brown Bag Seafood
Cava
Cavender's
Celis Juice Bar
Chopt
Chuze Fitness
City BBQ
Cooper's Hawk Winery and
Restaurant
CorePower Yoga
Corner Bakery

Dairy Queen
Darden Restaurants
Dave's Hot Chicken
Earls Restaurants
Emmy Squared Pizza
Escapology
Excel Fitness
First Watch
Foot Locker
Francesca's
Fresh Dining
FunBox
Glowbar
Go Bagels
Goop Kitchen
Half Price Books
Harold's Hallmark
Hattie B's
Hibbett Sporting Goods
Honeygrow
Inspire Brands
IT'SUGAR
J. Jill

JETSET Pilates
Jimmy the Greek
Joe & the Juice
Just Salad
k9 Resort
Kura Sushi
Landry's
Laynes Chicken
Lush
Marathon Coffee
Mendocino Farms
Moxie Coffee
Paris Baquette
Pause Studio
PickleRage
Ping Pod
Pizza Factory
Pure Gym
Qargo Coffee
Tim Horton's
Rhythm and Hues
Riser Fitness
Rowan
Soul Spice

Slice
Small Door Vet
Smoothie King
State of Play
Sugared+Bronzed
Summer Moon Coffee
SweatHouz
Sweetgreen
Swig
Taco Casa
Tatte Bakery and Café
The Candy Space
The Vitamin Shoppe
Toast City Diner
Towel Bar
Tropical Smoothie Café
Ville and Vine
Whataburger
Wetzel's Pretzels
Z-Burger

- › The Village: Increasing engagement
- › Colleyville Downs Restaurants:
- › Former Bellissimo's
- › 99 CENT STORE: Indoor amusement concepts, restaurant, grocery store
- › North (service restaurant)
- › North
- › South (it and Popular
Boutique)
- › Black Walnut: Mediterranean Restaurant
- › Zaifiro's: Fort Worth Restaurant



- › Colleyville Downs Restaurants: Drive Thru Potential
 - › Pizza chain and Coffee looking at former Daddy's/Zoe's
 - › Italian restaurant looking at former Blue Crab
- › Former Bellissimo's: Café and BBQ interest
- › 99 CENT STORE: Thrift Giant Purchase
- › Northern Gateway East: Garages of America with restaurant and retail under contract
- › Northern Gateway West: Upper/Upscale Resort Hotel under contract with developer
- › Southern Gateway: Developer LOI-Retail/Restaurant
- › Black Walnut: Truva is OPEN!
- › Zaifiro's: National chain interest

O'Brien Offices

609 Cheek-Sparger Road

3,507 Sq Feet



- Replacing the building that burned down
- Complete!

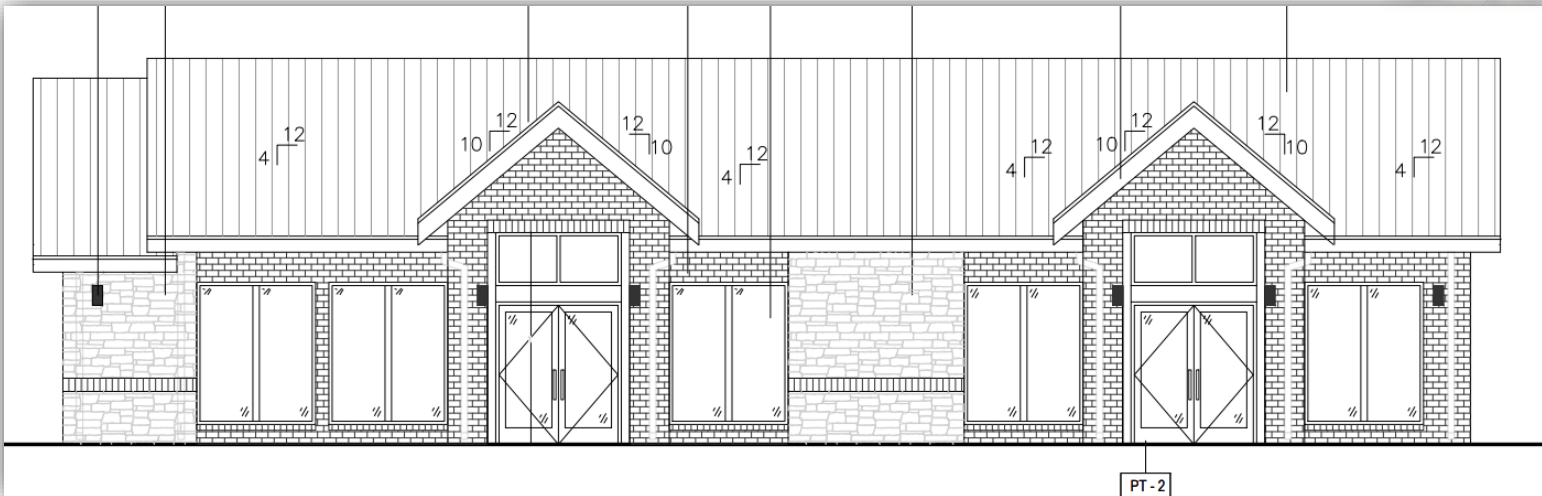

Golden Paws Development

1721 John McCain Road

4,596 Sq Feet



- Mobile veterinarian clinic proposed in one of 4 future buildings – 14,330 SQ feet total
- Remaining buildings to be used for office and office/showroom uses



Precinct Line Medical

8056 Precinct Line Road

4,696 Sq Feet



- Building 1 of 3 future office buildings
- In early stages of construction- in the framing process



Building 1



Building 2

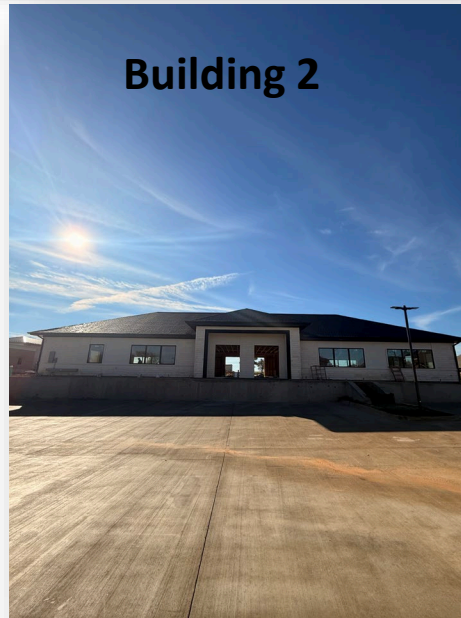

Building 3



Kiddie Academy

4321 Colleyville Boulevard

10,490 Sq Feet



- Still in early stages of construction-foundation preparation
- Early 2026 Opening



Sagora Senior Living

Cheek-Sparger Road and Wayne Drive

175,025 Sq Feet



- › Site plan approved
- › Plat approved
- › Building Permits expected soon



Kaizen Sports Training Facility

6609 Colleyville Boulevard

5,862 Sq Feet



➤ Building permits expected soon



City Owned Properties



➤ Northern Gateway 37 Acres

Under Contract for Upper/Upscale

Resort Hotel

Tree survey complete

Archeological survey complete – not a historical site



COLLEYVILLE TEXAS RESORT CONCEPTUAL ELEVATION

CONCEPT - NEOCLASSICAL ELEGANCE MEETS RUSTIC CHARM IN A LUXURIOUS RETREAT

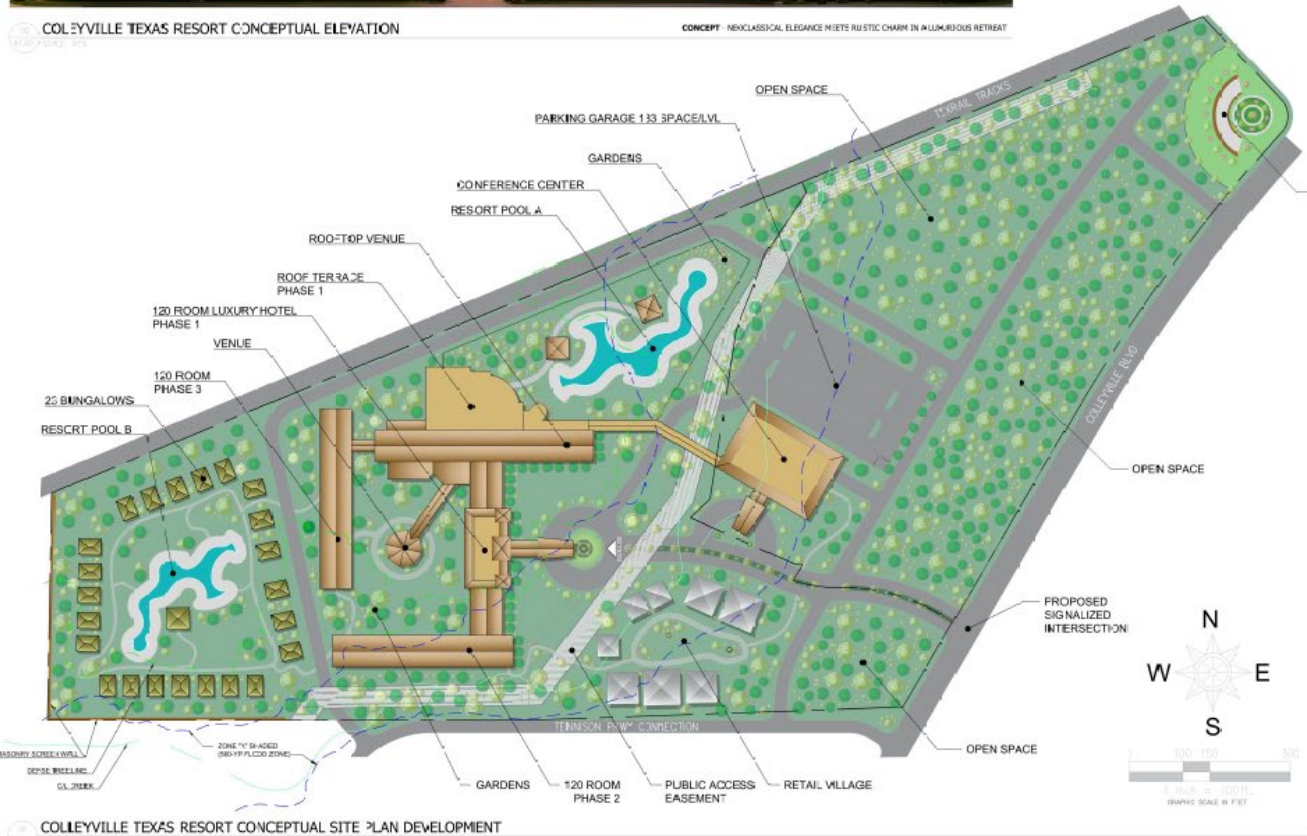

COLLEYVILLE TEXAS RESORT CONCEPTUAL SITE PLAN DEVELOPMENT

City Owned Properties



- Northern Gateway 3.81 Acres
Garages of America, Restaurant and Retail



City Owned Properties



- Southern Gateway 5.8856 Acres
LOI Retail and Restaurant



- **Business Center Chamber Partnership** – The City and the Chamber have partnered on a community Business Center. This facility is home to our Chamber of Commerce and provides support and programming for our local business community.
- **Business Outreach Program** – Staff makes personal contact with all business owners to discuss business trends and individual needs. City events also include business engagement opportunities.
- **Economic Development Committee-** Internal committee made of leadership roles throughout the organization. They meet to discuss trends, prospects, processes, and creative new ways to conduct business retention and attraction.
- **Economic Development Forum-** Monthly update conducted with the Colleyville Chamber of Commerce to inform the business community and residents about economic development happenings and request their prospect preference

Questions and Discussion



CITY OF COLLEYVILLE CITY COUNCIL BRIEFING

Agenda Number WS-3

Agenda Date 12/16/2025

Type Worksession

Department City Secretary

Title

Discussion of the December 16, 2025, City Council regular agenda items

Explanation

Attachments



CITY OF COLLEYVILLE CITY COUNCIL BRIEFING

Agenda Number 1

Agenda Date 12/16/2025

Type Executive Session

Department City Secretary

Title

Section 551.071 - Legal - Consultation with the City Attorney regarding items on the agenda or for matters in which the duty of the attorney to the governmental body under the Texas Disciplinary Rules of Professional Conduct of the State Bar of Texas clearly conflicts with Chapter 551 of the Texas Code

Section 551.072 - Real Estate - Deliberate the purchase, exchange, lease, or value of real property for City facilities

Section 551.087 - Economic Development - Discuss or deliberate regarding commercial or financial information the City has received from business prospects the City seeks to have locate, stay, or expand in the City and with which the City is conducting economic development negotiations; deliberate the offer of a financial or other incentive to a business prospect

Attachments

RESOLUTION R-25-5101

**A RESOLUTION APPROVING COUNCIL ACTION REGARDING
EXECUTIVE SESSION ITEMS AT THE REGULAR CITY COUNCIL
MEETING OF DECEMBER 16, 2025**

WHEREAS, following discussion in Executive Session, and in full accordance with the requirements of the Open Meetings Act, the City Council determines that the following action is in the best interests of the health, safety, and welfare of the public.

NOW, THEREFORE, BE IT RESOLVED BY THE CITY COUNCIL OF THE CITY OF COLLEYVILLE, TEXAS:

Sec. 1. THAT

AND IT IS SO RESOLVED.

APPROVED BY A VOTE OF _ AYES, _ NAYS ON THIS THE 16TH DAY OF DECEMBER 2025.

Mayor Bobby Lindamood	_____	Mark Alphonso, Place 2	_____
Mayor Pro Tem Brandi Elder	_____	Ben Graves, Place 4	_____
Deputy Mayor Pro Tem Scotty Richardson	_____	Tim Raine, Place 6	_____
Kimberly Holt Gunderson, Place 5	_____		

ATTEST:

CITY OF COLLEYVILLE

Christine Loven
City Secretary, TRMC

Bobby Lindamood
Mayor



CITY OF COLLEYVILLE CITY COUNCIL BRIEFING

Agenda Number 3

Agenda Date 12/16/2025

Type Announcements, Proclamations, and Presentations

Department City Secretary

Title

Proclamation in recognition of December as Season of Small Business - Mayor Bobby Lindamood and Chelsea Rose, Colleyville Community Engagement and Economic Development

Announcement of the 2025 Community Decorated Christmas Trees winners

Attachments

RESOLUTION R-25-5102

APPROVING CITY COUNCIL ACTION UNDER CONSENT ITEMS AT THE REGULAR CITY COUNCIL MEETING OF DECEMBER 16, 2025

WHEREAS, City Council has taken action on certain items on the agenda under Consent Items.

NOW, THEREFORE, BE IT RESOLVED BY THE CITY COUNCIL OF THE CITY OF COLLEYVILLE, TEXAS:

- Sec. 1. THAT the agenda decisions approved by City Council action under Consent Items as follows are hereby adopted:
 - a. Approval of the minutes of the regular City Council meeting of December 2, 2025
 - b. Approval of an Interlocal Agreement and Funding for the Metroport Teen Court Program

AND IT IS SO RESOLVED.

APPROVED BY A VOTE OF _ AYES, _ NAYS, ON THIS THE 16TH DAY OF DECEMBER 2025.

Mayor Bobby Lindamood	_____	Mark Alphonso, Place 2	_____
Mayor Pro Tem Brandi Elder	_____	Ben Graves, Place 4	_____
Deputy Mayor Pro Tem Scotty Richardson	_____	Tim Raine, Place 6	_____
Kimberly Holt Gunderson, Place 5	_____		

ATTEST:

CITY OF COLLEYVILLE

Christine Loven
City Secretary, TRMC

Bobby Lindamood
Mayor



CITY OF COLLEYVILLE CITY COUNCIL MINUTES

100 Main Street, Colleyville, Texas, 76034

TUESDAY, DECEMBER 2, 2025

Mayor Bobby Lindamood called the Colleyville City Council Worksession to order on Tuesday, December 2, 2025, at 5:30 p.m.

ROLL CALL: Mayor Bobby Lindamood, Mayor Pro Tem Brandi Elder, Deputy Mayor Pro Tem Scotty Richardson, and Councilmembers Mark Alphonso, Ben Graves, Kimberly Holt Gunderson, and Tim Raine.

ALSO PRESENT: Assistant City Manager Mark Wood, Assistant City Manager Adrienne Lothery, Police Chief Michael Miller, Fire Chief Mark Cantrell, Community Development Director Ben Bryner, Finance Director Cassie Smith, Public Works and Parks and Recreation Director Lisa Escobedo, Capital Projects Program Manager Elijah Dorminy, City Attorney Nocole Corr, and City Secretary Christine Loven.

WS-1 Discussion of a location for a second digital events sign

Assistant City Manager Adrienne Lothery presented this item which included two options for placement of the second digital sign. City Council directed staff to proceed with placing a sign at the southeast corner of Colleyville Boulevard and Glade Road.

WS-2 Discussion of legal counsel rate increase

City Attorney Nicole Corr reviewed the City's fee structure for legal services and reviewed the fee schedule going forward which is an increase of approximately 5.6%, and is the firm's second increase in ten years.

WS-3 Discussion of the December 2, 2025, City Council regular agenda items

There was no discussion of this item.

Mayor Lindamood adjourned the Worksession at 5:41 p.m. and called Executive Session to order.

1. EXECUTIVE SESSION - In accordance with Texas Government Code, Chapter 551, Subchapter D

Section 551.071 - Legal - Consultation with the City Attorney regarding items on the agenda or for matters in which the duty of the attorney to the governmental body under the Texas Disciplinary Rules of Professional Conduct of the State Bar of Texas clearly conflicts with Chapter 551 of the Texas Code

Section 551.072 - Real Estate - Deliberate the purchase, exchange, lease, or value of real property for City facilities

Section 551.087 – Economic Development - Discuss or deliberate regarding commercial or financial information the City has received from business prospects the City seeks to have locate, stay, or expand in the City and with which the City is conducting economic development negotiations; deliberate the offer of a financial or other incentive to a business prospect

There was no action taken and Mayor Lindamood adjourned Executive Session at 6:51 p.m.

Mayor Lindamood called the regular meeting of the City Council to order at 7:03 p.m. and called the roll.

ROLL CALL: Mayor Bobby Lindamood, Mayor Pro Tem Brandi Elder, Deputy Mayor Pro Tem Scotty Richardson, and Councilmembers Mark Alphonso, Ben Graves, Kimberly Holt Gunderson, and Tim Raine.

INVOCATION: Mayor Lindamood
PLEDGE OF ALLEGIANCE: City Attorney

2. EXECUTIVE SESSION READING AND PUBLIC HEARING: CONSIDER AND TAKE ANY ACTION(S) NECESSARY RELATIVE TO ITEMS DISCUSSED IN EXECUTIVE SESSION - RESOLUTION R-25-5098

This resolution was not needed.

3. ANNOUNCEMENTS, PROCLAMATIONS, AND PRESENTATIONS

Mayor Lindamood and the City Council provided announcements regarding community news and upcoming events.

Presentation by Director Rich Anderson, International Code Council, Inc. recognizing City Inspector Richard Clark

Richard C. Anderson, Director, PMG Technical Resources, International Code Council, thanked Mayor Lindamood and the City Council for the opportunity to recognize Colleyville Building Inspector Richard Clark, for his leadership, strategic vision, and unwavering commitment to excellence while serving the International Code Council.

4. CONSENT: READING AND PUBLIC HEARING - RESOLUTION R-25-5099

- 4a** Approval of the minutes of the City Council meeting of November 18, 2025
- 4b** Approval of a three-year Municipal and County Government Enterprise License Agreement (ELA), between the City of Colleyville and the Environmental Systems Research Institute, Inc. (Esri), for Citywide ArcGIS services, in an amount not to exceed \$90,600, and authorizing the City Manager to execute the agreement
- 4c** Approval of a construction contract with Canary Construction, Inc. for emergency drainage culvert repairs, in an amount not to exceed \$86,670, a contingency amount not to exceed \$9,000, and authorizing the City Manager to execute the contract
- 4d** Approval to purchase a replacement vacuum street sweeper from Closner Equipment Co., Inc., through the Sourcewell Purchasing Program in an amount not to exceed \$349,135, approving the disposal of the unit being replaced, and authorizing the City Manager to execute the contract
- 4e** Approval of an Interlocal Agreement with Tarrant County for the rehabilitation of various streets as identified in the agreement, and authorizing the City Manager to execute the agreement
- 4f** Approval of a Professional Services Agreement with Westra Consultants, in an amount not to exceed \$60,000, for the design of the Drinking Water Risk and Resilience Assessment Update, and authorizing the City Manager to execute the agreement
- 4g** Nominating George Dodson to fill the Tarrant Appraisal District Board of Directors vacancy for a term to December 31, 2027
- 4h** Changing the dates of several regularly scheduled 2026 City Council Meetings to accommodate holidays when the City is closed, GCISD Spring Break, National Night Out, and Election Day

Mayor Lindamood read Resolution R-25-5099 in its entirety.

Information Systems Manager Patrick Stotts presented item 4b.

Public Works Director Lisa Escobedo presented item 4c. through 4f. There was discussion regarding the culvert repairs (4c.) in relation to planned construction on Cheek-Sparger Road.

City Secretary Christine Loven presented item 4g. and 4h. There was no additional discussion.

Mayor Lindamood opened and closed the public hearing without any speakers.

Councilmember Alphonso made a motion to approve Resolution R-25-5099 seconded by Councilmember Holt Gunderson.

The motion was approved by the following vote:

Ayes: 7 – Mayor Bobby Lindamood, Mayor Pro Tem Brandi Elder, Deputy Mayor Pro Tem Scotty Richardson, and Councilmembers Mark Alphonso, Ben Graves, Kimberly Holt Gunderson, and Tim Raine.

5. ORDINANCE(S): FIRST READING AND PUBLIC HEARING

5a Ordinance O-25-2356

Consideration of a Special Use Permit for an Accessory Building for Lot 3, Block 1, Beldon Hollow, located at 4905 Beldon Trail, Case ZC25-029

Mayor Lindamood read the caption of Ordinance O-25-2356.

Community Development Director Ben Bryner presented the request to allow an accessory building which exceeds the combined square footage of all accessory buildings on a lot.

The applicant, Rodney Owens, and the homeowner, Brian Steffek, were present to answer questions of the City Council. Mr. Steffek agreed to reduce the width of the building to reduce the percentage of the size overage.

Mayor Lindamood opened and closed the public hearing without any speakers.

This was a first reading with no action taken.

6. CITIZEN COMMENTS

There were no speakers.

7. ACTION/RESOLUTION: DISCUSSION AND CONSIDERATION OF A RESOLUTION RATIFYING COUNCIL AGENDA ACTION FOR TUESDAY, DECEMBER 2, 2025 - READING AND PUBLIC HEARING - RESOLUTION R-25-5100

This resolution was not needed.

8. ADJOURNMENT

There being no further business before the City Council, Mayor Lindamood adjourned the meeting without objection by the City Council at 8:02 p.m.

Minutes taken and prepared by:

*Christine Loven, TRMC
City Secretary*



CITY OF COLLEYVILLE CITY COUNCIL BRIEFING

Agenda Number 4b

Agenda Date 12/16/2025

Number Resolution R-25-5102

Type Resolution

Department Municipal Court

Title

Approval of an Interlocal Agreement and funding for the Metroport Teen Court Program

Explanation

Reading and Public Hearing

Since 1994, the City of Colleyville has participated in the Metroport Teen Court program with the cities of Grapevine and Southlake. Fiscal Year 2011 was the first year the City of Keller participated in the program.

Attached is the proposed Interlocal Agreement for the Metroport Teen Court for Fiscal Year 2026, for an annual cost of \$36,000. The cost of the program is split equally between the four participating cities.

Per the attached memo, in Fiscal Year 2025, there were 41 Colleyville referrals to Metroport Teen Court program, down from 44 in FY2024.

Approval will provide for the City's continuation in the Metroport Teen Court program.

Financial Impact

Funding in the amount of \$33,000 was approved in the Fiscal Year 2026 Colleyville Crime Control and Prevention District budget. The remaining \$3,000 is funded out of the Court Building Security Fund for bailiff security services provided during teen court sessions.

Recommendation

Approve

Attachments

1. Metroport Teen Court Presentation
2. Colleyville Interlocal Agreement Memo FY26
3. FY26 Metroport Teen Court Interlocal Agreement

4b. Metroport Teen Court ILA and Funding



Metroport Teen Court Advisory Board Members and Municipal Court Judges

City Served	Title	Name
Southlake	City Council Member	Chuck Taggart
Southlake	Representative	Devika Seth
Southlake	Representative	Kara Carreras
Southlake	Municipal Court Judge	Carol Montgomery
Colleyville	City Council Member	Tim Raine
Colleyville	Representative	Susan Baum
Colleyville	Representative	Sayeda Syed
Colleyville	Municipal Court Judge	Carol Montgomery
Grapevine	City Council Member	Sean Shope
Grapevine	Representative	Marjorie Lewis
Grapevine	Representative	Kevin Sellers
Grapevine	Municipal Court Judge	Alan Wayland
Keller	City Council Member	Tag Green
Keller	Representative	
Keller	Representative	Jennifer Larson
Keller	Municipal Court Judge	Carol Montgomery

Referrals per city (Percentages) FY2025

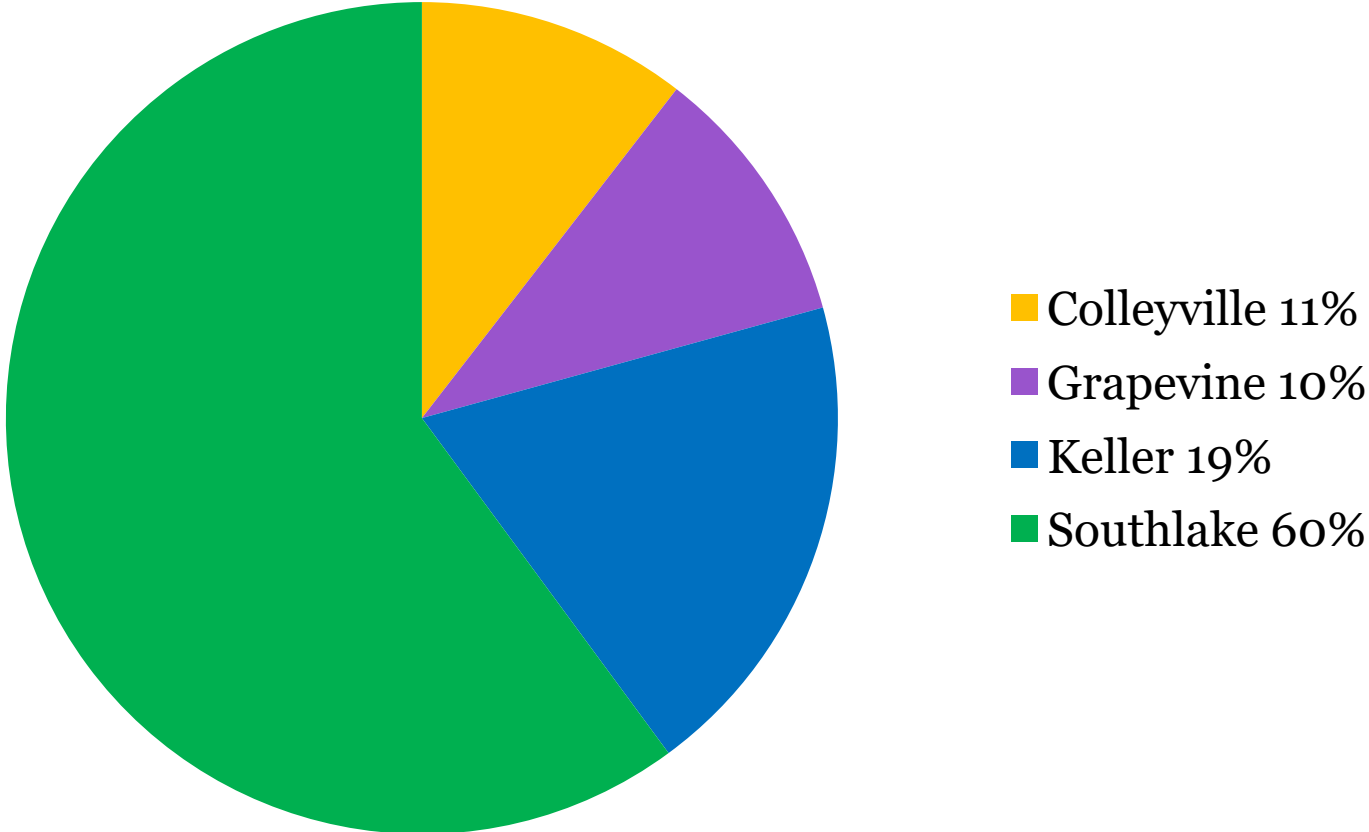

These numbers reflect the total number of referrals filed in the cities of Colleyville, Keller, Grapevine, and Southlake that were granted Teen Court.

Teen Court Traffic Violations FY2025

Type	Number	Percentage
Traffic violations	303 ↓	
Speeding/SP in a SZ	170	56%
Violate DL Restrictions	37	12%
Ran Stop Signs/Red Lights	17	6%
Seatbelt Violations	13	4%
Lane Departures	13	4%
Other	53	18%
TOTALS	303	100%

Failures to Complete – FY 2025

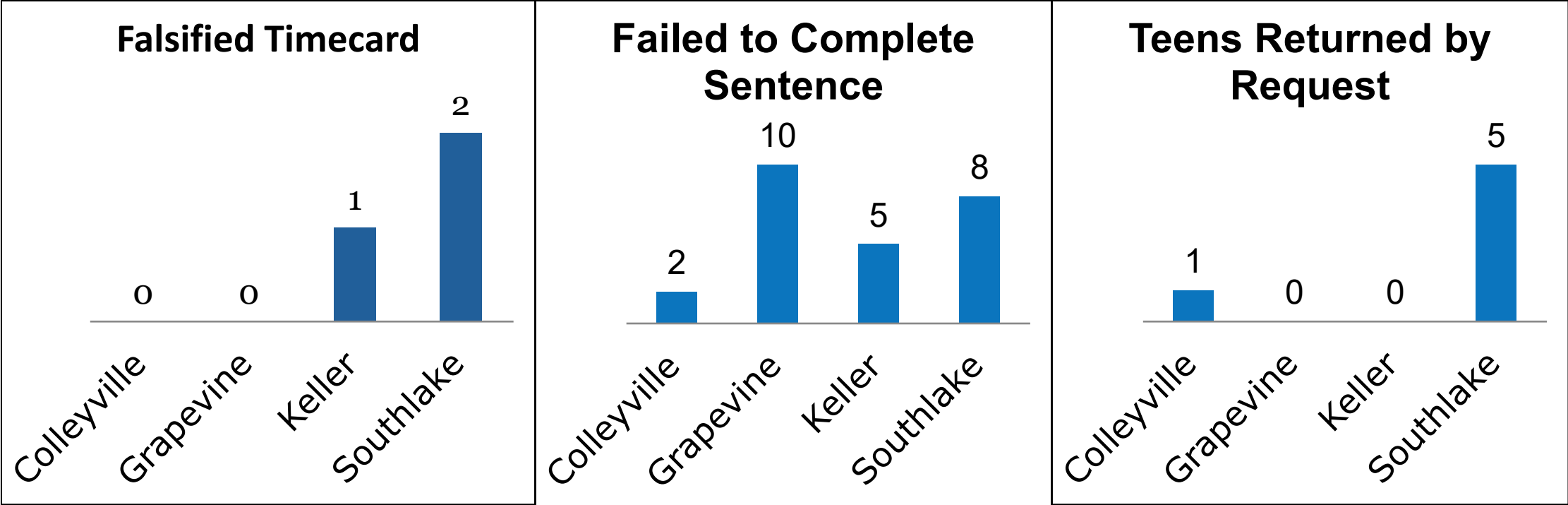

Completions – Yearly Success Rate

Total Referrals – 391 cases

Failures and Returns – 33 cases

**92% Completion Rate for FY
2025**



MEMORANDUM

October 1, 2025

TO: Karen Hines, Colleyville Finance Manager

FROM: Dana Kirkland, Metroport Teen Court Supervisor

SUBJECT: Interlocal Agreement for funding of the Teen Court Program

The attached FY 2026 Interlocal Agreement outlines the Metroport Teen Court Program, as well as the appointment process for the Metroport Teen Court Advisory Board. The City of Southlake is grateful for Colleyville’s contribution of \$36,000 and its continued support of the Metroport Teen Court program. The agreement defines the duties of Board members and authorizes the City of Southlake to employ Teen Court staff. Also discussed in the contract is the City of Southlake’s responsibility to provide office space for staff and collect an equal share in cost from the other participating Cities for program maintenance.

Metroport Teen Court has a success rate of 93%. Listed below is the requested data of Teen Court referrals for the City of Colleyville:

- FY 2025: 41 Case Referrals from the City of Colleyville
- FY 2025: 391 Total Referrals for the cities of Colleyville, Grapevine, Keller, and Southlake

Historical Data of Metroport/Colleyville Referrals:

<u>Year</u>	<u>Total Referrals</u>	<u>Colleyville Referrals</u>
FY 2010	1064	255
FY 2011	1024	187
FY 2012	1062	215
FY 2013	914	119
FY 2014	773	107
FY 2015	760	117
FY 2016	761	118
FY 2017	717	80
FY 2018	638	87
FY 2019	550	74
FY 2020	481	73
FY 2021	386	55
FY 2022	499	117
FY 2023	437	69
FY 2024	396	44

Metroport Teen Court would like to thank the City of Colleyville for its long-standing and continued support and look forward to a lasting relationship. Should you need any further information and/or data, please feel free to contact Dana Kirkland at (817) 748-8346.

INTERLOCAL AGREEMENT

AMONG

CITY OF COLLEYVILLE, CITY OF GRAPEVINE, CITY OF KELLER, AND CITY OF SOUTHLAKE

This Interlocal Agreement (“Agreement”), entered into effective on the 1st day of October, 2025, by and among the City of Colleyville, the City of Grapevine, City of Keller, and the City of Southlake, all municipal corporations of the State of Texas (herein called “Cities” or “each participating City”), the parties acting herein under the authority and pursuant to the terms of Chapter 791, INTERLOCAL COOPERATION CONTRACTS, Texas Government Code, **WITNESSETH THAT:**

WHEREAS, the City Councils of the Cities of Colleyville, Grapevine, Keller, and Southlake jointly find that it will be in the publics’ best interest to enter into this Agreement for the purposes set forth herein below.

NOW, THEREFORE, it is mutually agreed between each participating City that:

1. Teen Court is a volunteer program which allows juvenile misdemeanor offenders an alternative to the criminal justice system while allowing them also to assume responsibility for their own actions through their involvement in the judicial process and community services in order that their offenses will not be recorded as a conviction on their driving record. Bringing juvenile offenders to a jury of their peers and to the community for constructive punishment will provide the juveniles with an understanding of the judicial system and a realization of their roles and responsibilities in the community.

2. The community will benefit from this interaction in that, through Teen Court, the community is afforded a unique opportunity to become involved in the education of juvenile offenders and will benefit from the community services provided to the community by the juvenile offenders.

3. A Teen Court Advisory Board shall be appointed by the respective governing bodies comprised of two (2) members at large from each participating City and one (1) city council member from each participating City as each so chooses all of whom are voting members. The role and duties of the Teen Court Advisory Board shall be established by the Municipal Court

Judges in the participating Cities.

4. The name of the program established by this Agreement shall be the “METROPORT Teen Court Program.” The City of Southlake shall employ teen court staff to administer and coordinate the activities of the METROPORT Teen Court Program, under the direction of the Southlake Municipal Court Manager.

5. This Agreement shall be executed in separate counterparts for each participating city, which counterparts shall be valid and binding as if the original. Each participating city, as its contribution for participating in the METROPORT Teen Court Program, shall pay to the City of Southlake \$36,000.00 (“Service Fee”) upon such participating City’s execution of this Agreement. It is expressly agreed that such payment fairly compensates the City of Southlake for the performance of services contemplated under this Agreement. Each participating City shall make this payment from current revenues available to that City.

6. The scope of responsibilities of the Teen Court Staff shall be established by the City of Southlake.

7. The term of this Agreement shall be for a period of (12) twelve months beginning October 1, 2025, and ending September 30, 2026. If the parties have failed to adopt a new Agreement by the expiration date of this Agreement, this Agreement shall be deemed to continue on the same terms and conditions until such time as the new Agreement is adopted for the ensuing year, unless any party terminates its participation in this Agreement as provided below. In such event, this Agreement shall continue in effect until either the City of Southlake or all other participating Cities have terminated this Agreement. Upon renewal or continuation of this Agreement, each participating City shall pay the Service Fee to the City of Southlake for the ensuing year.

8. Any party hereto may terminate its participation in this Agreement without recourse or liability upon thirty (30) days written notice to the other party.

9. By execution of this Agreement, each party represents to the other that:

- a. In performing its duties and obligations hereunder, it will be carrying out one or more governmental functions or services which it is

authorized to perform; and

- b. The undersigned officer or agent of the party has been properly authorized by that party's governing body to execute this Agreement and that any necessary resolutions extending such authority have been duly passed and are now in effect.
11. This Agreement is made pursuant to Chapter 791 and Subchapter E, Chapter 418, Texas Government Code. It is agreed that in the execution of this Agreement, no party waives any immunity or defense that would otherwise be available to it, against claims arising from the exercise of governmental powers and functions.

ATTEST:

City Secretary, City of Colleyville Date _____
Mayor, City of Colleyville Date

City Secretary, City of Grapevine Date _____
Mayor, City of Grapevine Date

City Secretary, City of Keller Date _____
Mayor, City of Keller Date

City Secretary, City of Southlake Date _____
Mayor, City of Southlake Date

Approved as to form and legality:

City Attorney, City of Colleyville _____
City Attorney, City of Grapevine

City Attorney, City of Keller _____
City Attorney, City of Southlake



CITY OF COLLEYVILLE CITY COUNCIL BRIEFING

Agenda Number 5a

Agenda Date 12/16/2025

Type Report

Department Finance

Title

Monthly Financial Report - November 2025

Explanation

Staff will present the November 2025 Financial Report.

Attachments

1. November 2025 - Monthly Budget vs Actual

**City of Colleyville
Monthly Budget vs Actual Report
November 30, 2025**

	FY 2026				FY 2025				
	Annual Budget	Actual Thru Mth	Variance Annual	% of Annual Bdg	Annual Actual YTD	Actual Thru Mth	Variance Annual	% of Annual Act	% chg from PY
General Fund									
Current Taxes	18,870,816	221,996	18,648,820	1.2%	17,951,811	-	17,951,811	0.0%	0.0%
Delinquent	30,000	17,458	12,542	58.2%	26,739	3,751	22,989	14.0%	365.5%
P&I	80,000	3,708	76,292	4.6%	89,241	2,173	87,069	2.4%	70.6%
Property Tax Total	18,980,816	243,162	18,737,654	1.3%	18,067,791	5,923	18,061,868	0.0%	4005.2%
Sales Tax	5,304,000	-	5,304,000	0.0%	4,670,258	-	4,670,258	0.0%	0.0%
Oncor Electric	910,000	-	910,000	0.0%	887,583	-	887,583	0.0%	0.0%
Tri-County Electric	185,000	-	185,000	0.0%	172,925	-	172,925	0.0%	0.0%
Atmos Gas	600,000	-	600,000	0.0%	682,980	-	682,980	0.0%	0.0%
AT&T	15,000	7,278	7,722	48.5%	9,534	2,522	7,012	26.5%	188.5%
Verizon/Others	12,000	1,760	10,240	14.7%	7,462	2,009	5,454	26.9%	-12.4%
Refuse/Recycling	300,000	16,348	283,652	5.4%	313,431	15,731	297,700	5.0%	3.9%
Cable TV	200,000	25,486	174,515	12.7%	186,044	30,248	155,796	16.3%	-15.7%
Network Nodes	250	-	250	0.0%	250	-	250	0.0%	0.0%
Franchise Fees	2,222,250	50,871	2,171,379	2.3%	2,260,209	50,510	2,209,699	2.2%	0.7%
GF Revenues	31,285,851	873,820	30,412,031	2.8%	30,206,174	776,121	29,430,053	2.6%	12.6%
GF Expenditures	31,268,504	5,001,429	26,267,075	16.0%	28,806,482	4,535,696	24,270,785	15.7%	10.3%
Utilities Fund									
Water - Base Rate	2,509,730	412,768	2,096,962	16.4%	2,392,687	398,945	1,993,741	16.7%	3.5%
Sewer - Base Rate	1,885,685	310,293	1,575,392	16.5%	1,734,664	288,917	1,445,747	16.7%	7.4%
Water - Volumetric Rate	17,072,779	1,665,341	15,407,438	9.8%	14,533,462	3,070,563	11,462,899	21.1%	-45.8%
Sewer - Volumetric Rate	4,956,120	357,874	4,598,246	7.2%	4,536,672	704,110	3,832,562	15.5%	-49.2%
Water & Sewer	26,424,314	2,746,276	23,678,038	10.4%	23,197,484	4,462,535	18,734,949	19.2%	-38.5%
Utilities Revenues	27,013,314	2,855,061	24,158,253	10.6%	25,432,140	4,629,472	20,802,668	18.2%	-38.3%
Utilities Expenditures	26,855,702	3,595,474	23,260,228	13.4%	21,190,559	2,405,296	18,785,263	11.4%	49.5%
Debt Service Fund									
Current Taxes	924,135	13,354	910,781	1.4%	911,283	-	911,283	0.0%	0.0%
Delinquent	2,000	999	1,001	50.0%	1,022	143	879	14.0%	598.9%
P&I	3,400	201	3,199	5.9%	5,196	83	5,113	1.6%	141.7%
Property Tax Total	929,535	14,554	914,981	1.6%	917,501	226	917,275	0.0%	6337.8%
DS Revenues	1,702,645	14,652	1,687,993	0.9%	1,473,411	226	1,473,185	0.0%	6381.1%
DS Expenditures	1,693,245	318,485	1,374,760	18.8%	1,540,145	168,485	1,371,660	10.9%	89.0%
Drainage Fund									
Drainage Fee	2,021,000	211,374	1,809,626	10.5%	1,732,717	288,632	1,444,085	16.7%	-26.8%
Drain Revenues	2,061,000	223,023	1,837,977	10.8%	1,793,001	296,390	1,496,611	16.5%	-24.8%
Drain Expenditures	1,994,787	113,428	1,881,359	5.7%	737,263	114,606	622,657	15.5%	-1.0%
Hotel Occupancy Tax (HOT) Fund									
HOT Tax	230,000	-	230,000	0.0%	378,077	-	378,077	0.0%	0.0%
HOT Revenues	230,000	29	229,971	0.0%	378,117	-	378,117	0.0%	0.0%
HOT Expenditures	260,439	39,785	220,654	15.3%	508,670	35,808	472,862	7.0%	11.1%

Note: The financial figures presented are unaudited and subject to change pending final audit adjustments.



CITY OF COLLEYVILLE CITY COUNCIL BRIEFING

Agenda Number 6a

Agenda Date 12/16/2025

Number Ordinance O-25-2356

Type Ordinance

Department Community Development

Title

Consideration of a Special Use Permit for an Accessory Building for Lot 3, Block 1, Beldon Hollow, located at 4905 Beldon Trail, Case ZC25-029

Explanation

Second Reading and Public Hearing

The applicant and homeowner presented the case and answered questions from the City Council. The City Council asked if the width of the building could be reduced to 20 feet. The homeowner agreed. This would reduce the size to 1,400 square feet, which is 4.8% of the lot area. No one from the audience came forward to speak during the public hearing.

First Reading and Public Hearing

Rodney Owens, the applicant, has submitted a request for a Special Use Permit (SUP) to allow for an Accessory Building on Lot 3, Block 1, Beldon Hollow, being approximately 0.66 acres and zoned PUD-R Planned Unit Development - Residential. The request is to allow for an accessory building that does not conform to the Land Development Code, Section 3.27(A)(2)(a). The proposal would exceed four percent (4%) of the aggregate area of the lot, which is the maximum allowed by the Land Development Code, unless granted an SUP.

Existing Conditions/Background: The subject property, 4905 Beldon Trail, resides south of the intersection of Beldon Trail and Glade Road. The property is developed with a single-family home and an existing accessory shade structure.

SUP Request: The applicant is requesting a SUP to allow for an accessory building which would exceed the requirements as permitted by the Land Development Code, Section 3.72(A)(2)(a):

“The maximum number of accessory buildings allowed per lot shall be three (3) buildings. In addition, the combined square footage of all accessory buildings shall not exceed four percent (4%) of the aggregate area of the lot.”

Analysis: The subject property is 29,051 square feet, which allows 1,162 square feet (4%) for accessory buildings. The existing accessory structure is 278 square feet and the proposed accessory building would be 1,878 square feet. Together, the buildings

would be 2,143 square feet (7.4%), exceeding four percent (4%) of the aggregate lot area.

Plat Status: The property is platted as Lot 3, Block 1, Beldon Hollow.

DRC Review: The DRC reviewed the request during their October 20, 2025, meeting and determined the case would be scheduled for the November 10, 2025, Planning and Zoning Commission meeting.

Drainage: N/A

Surrounding Development: The properties to the north, south, and west are zoned PUD-R Planned Unit Development - Residential and are improved with single-family homes. The properties to the east are zoned R-30 Single Family Residential and are developed with single-family homes.

Comprehensive Plan: The City's comprehensive plan, *Destination Colleyville*, identifies the subject property for residential development. The proposed SUP does not conflict with any portion of the comprehensive plan.

Public Notification: Staff mailed notices to all property owners within 500 feet as well as any Homeowners Associations within 1,000 feet of the subject property regarding this request. Grapevine-Colleyville ISD, where the subject property is located, was notified per State law. Notice was published in the *Fort Worth Star-Telegram* as required by State law and the Land Development Code.

Staff Recommendation: Staff recommends approval for this request.

Planning and Zoning Commission Recommendation: The Planning and Zoning Commission recommended approval of the request at their November 10, 2025 meeting by a vote of 5-1.

Financial Impact

There is no financial impact to the City.

Recommendation

Approve

Attachments

1. Aerial Map
2. Zoning Map
3. Future Land Use Map
4. Statement of Planning Objectives
5. Site Plan
6. Elevations

7. Letters of Support
8. Notification Map
9. Notification Letter
10. Ordinance O-25-2356

Aerial Map

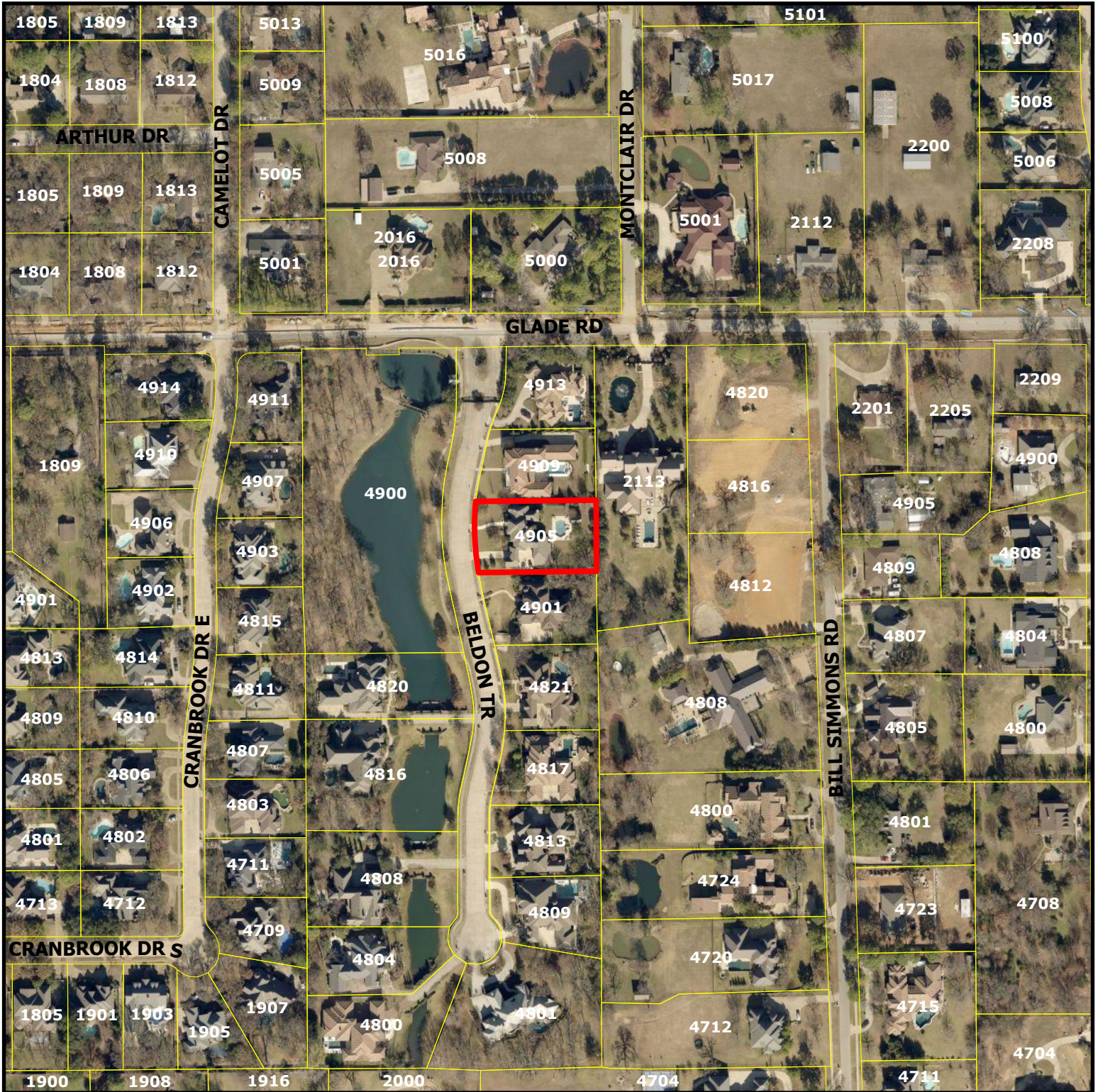

ZC25-029

4905 Beldon Trail

DISCLAIMER:
 This map and information contained in it were developed exclusively for use by the City of Colleyville. Any use or reliance on this map by anyone else is at that party's risk and without liability to the City of Colleyville, its officials or employees for any discrepancies, errors, or variances which may exist.

 Subject Property

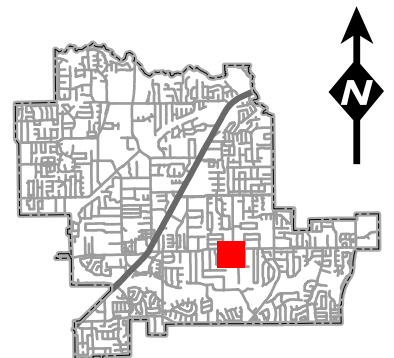

Zoning Map

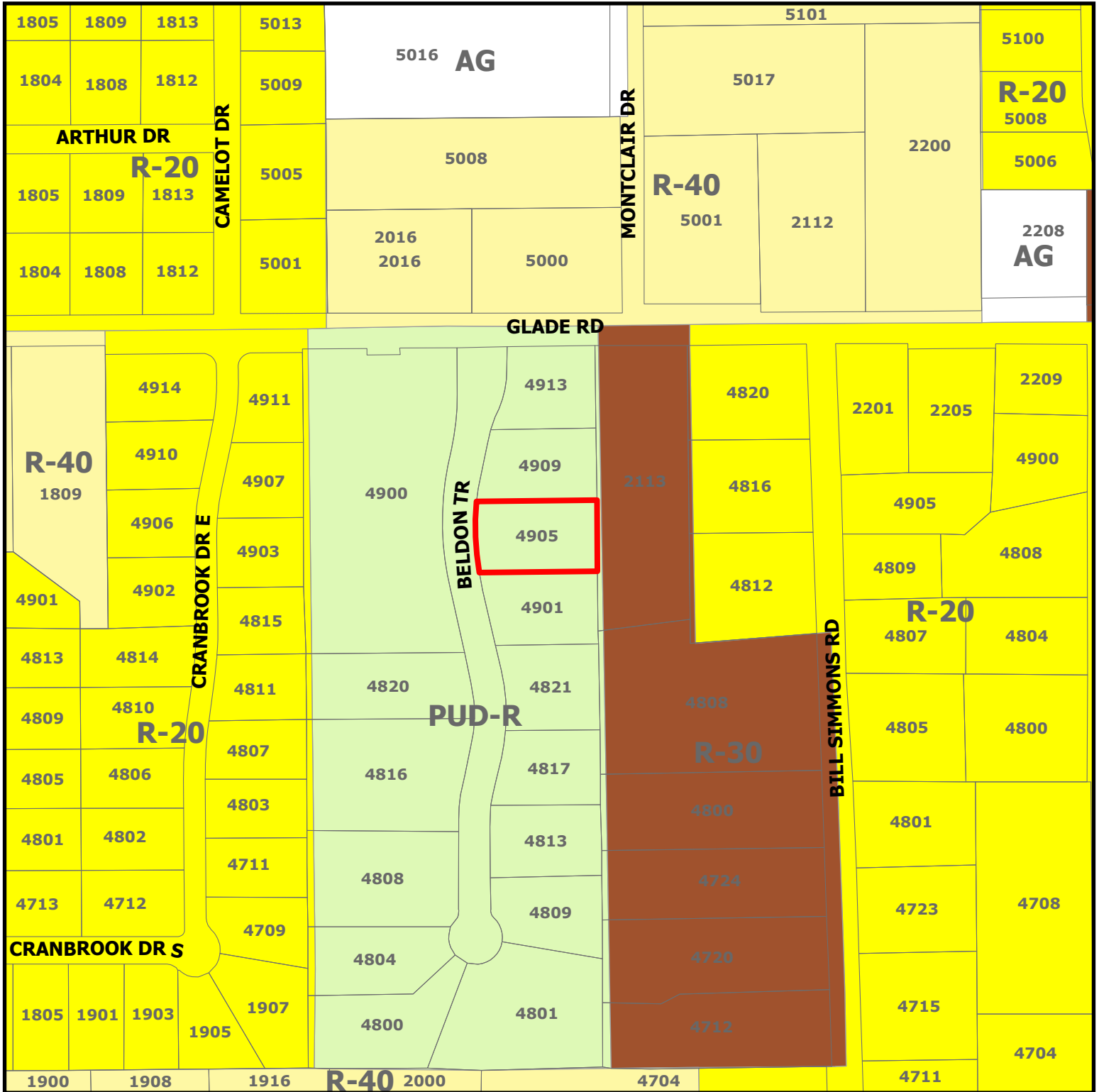

ZC25-029

4905 Beldon Trail

 Subject Property

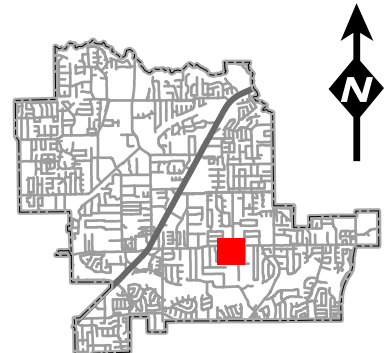

DISCLAIMER:
 This map and information contained in it were developed exclusively for use by the City of Colleyville. Any use or reliance on this map by anyone else is at that party's risk and without liability to the City of Colleyville, its officials or employees for any discrepancies, errors, or variances which may exist.

Future Land Use Map



ZC25-029

4905 Beldon Trail

- Residential
- Water Body
- Subject Property

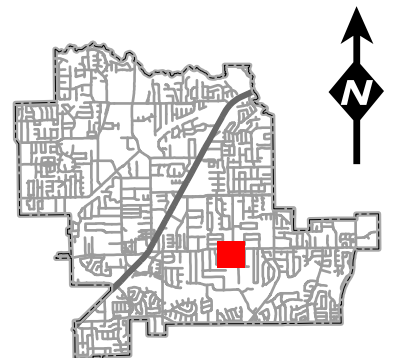

DISCLAIMER:
 This map and information contained in it were developed exclusively for use by the City of Colleyville. Any use or reliance on this map by anyone else is at that party's risk and without liability to the City of Colleyville, its officials or employees for any discrepancies, errors, or variances which may exist.

10 October 2025

Request for Home Improvement Project Approval

Brian & Amy Steffek
4905 Beldon Trail
Colleyville, TX 76034

To Whom It May Concern,

The reason for the construction project is to spend more time with the family at home in the beautiful Beldon Hollow neighborhood. We will use this area for entertainment and family activities as the kids grow up over the next 10 years and our social network expands in the Colleyville community overall.

Please consider for approval our request for a home improvement project for a structural addition to our backyard per the details included in this package to the City of Colleyville. We will utilize local Colleyville resources for Engineering, Construction Services, and materials where applicable for this project to maximize the local content. Our plans for this multi-purpose room meet all property boundary requirements and elevation limitations. This detached, one-story structure will be made to seamlessly match the existing home with the like materials for brick, roofing, and paint colors. There will not be any plumbing inside the structure as it will not be an inhabited addition by the family.

Thank you for your consideration.

Sincerely,

Brian & Amy Steffek

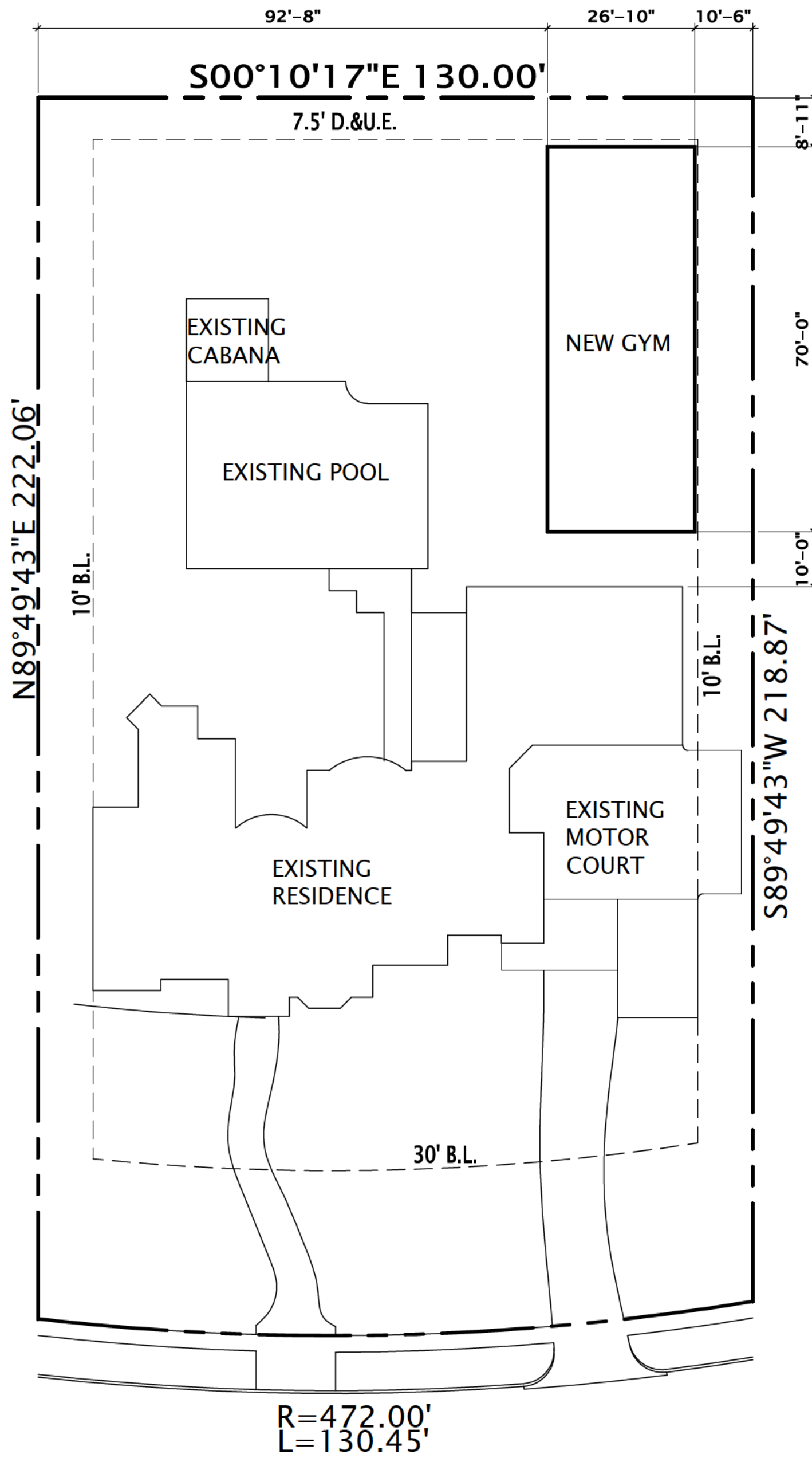

LOT COVERAGE ALLOWANCES	
NEW FOUNDATION	1,878 SQ. FT.
EXISTING FOUNDATION	5,065 SQ. FT.
FLATWORK SQ. FT. (1858+1081)	2,939 SQ. FT.
POOL, PATIO & OTHER COVERAGE SQ. FT.	1,903 SQ. FT.
TOTAL COVERAGE SQ. FT.	11,785 SQ. FT.
29,051 SQ. FT. LOT	
60 % MAXIMUM COVERAGE ALLOWED	40.57% COVERAGE

LOT 3 BLOCK 1
 BELDON HOLLOW
 CITY OF COLLEYVILLE
 TARRANT COUNTY, TX
SITE PLAN



SCALE: 1" = 20'-0"

THE DESIGN STUDIO OF
JAMIE LINN

817-733-7173

LOT 3 BLOCK 1
 4905 BELDON TRAIL
 COLLEYVILLE, TX

STEFFEK RESIDENCE
BUILDER CUSTOM HOMES

SP. 1
 OF 1 SHEETS





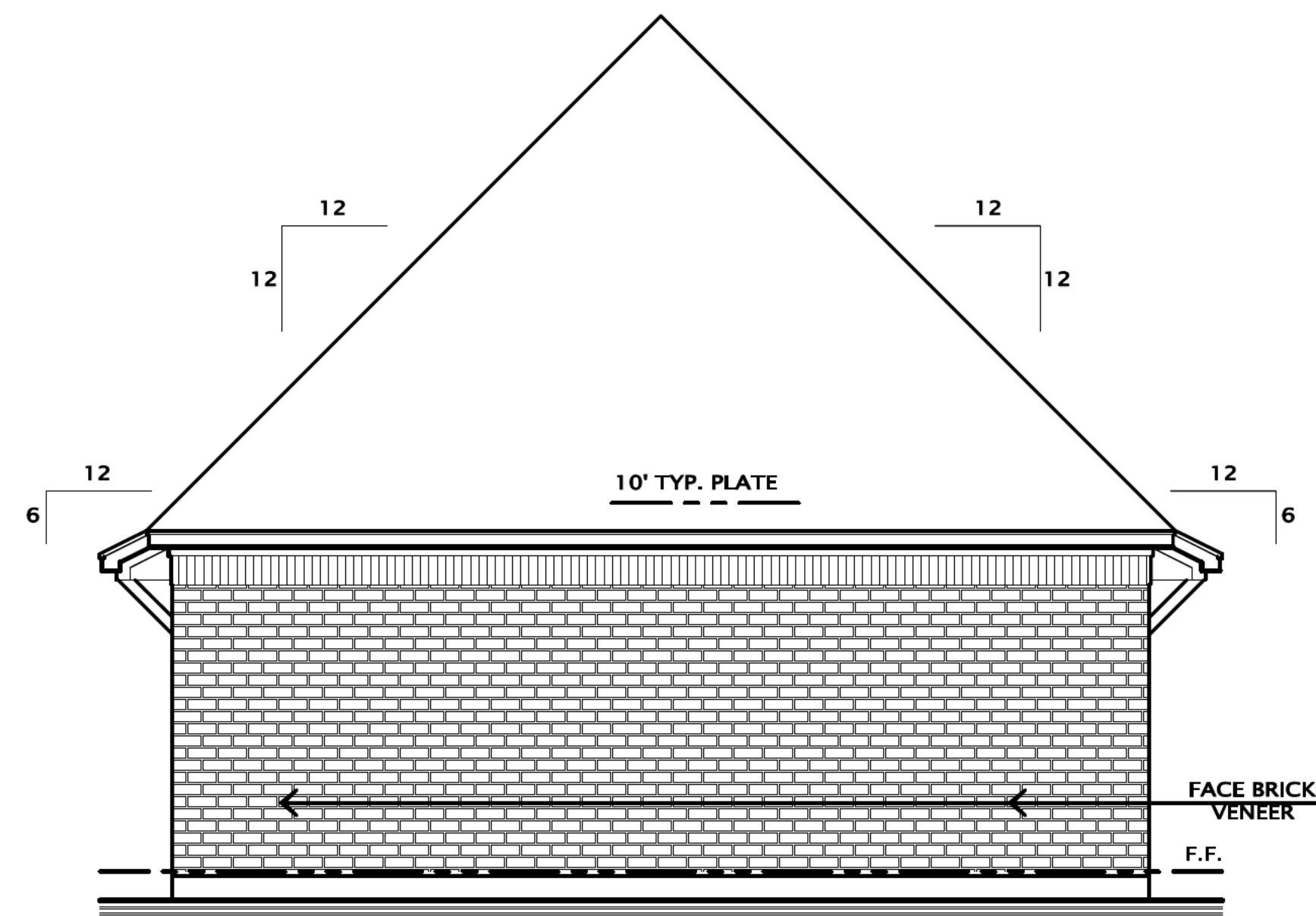

SIDE ELEVATION

SCALE: 1/4" = 1'-0"

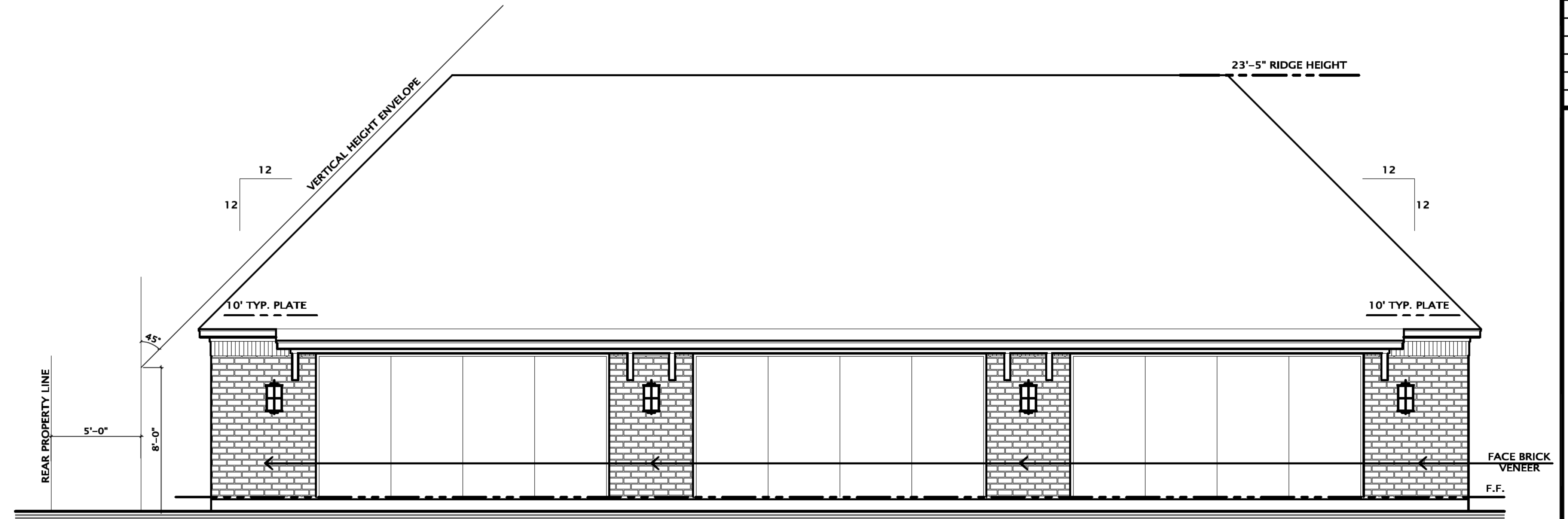

FRONT ELEVATION

SCALE: 1/4" = 1'-0"

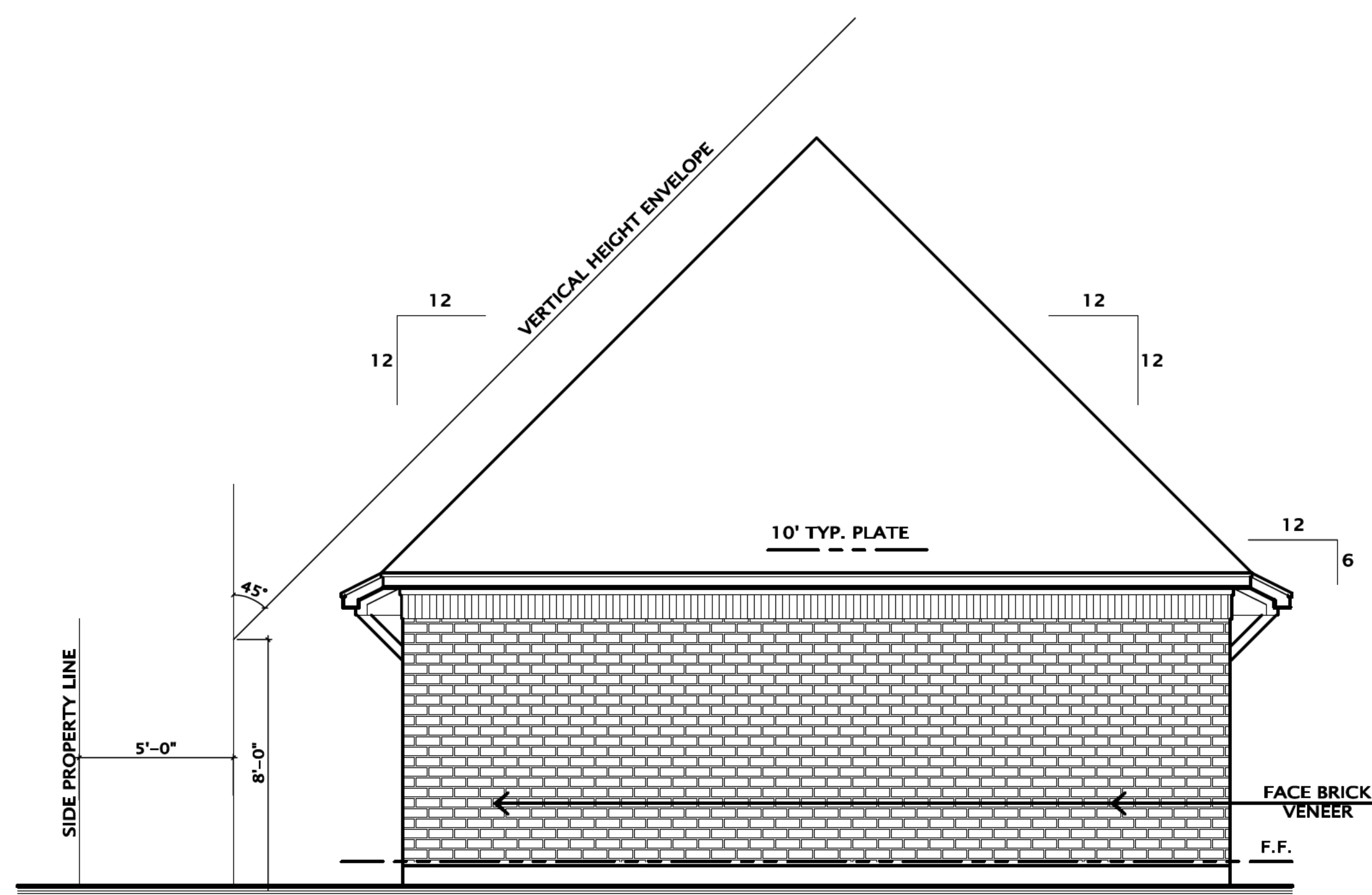

SIDE ELEVATION

SCALE: 1/4" = 1'-0"

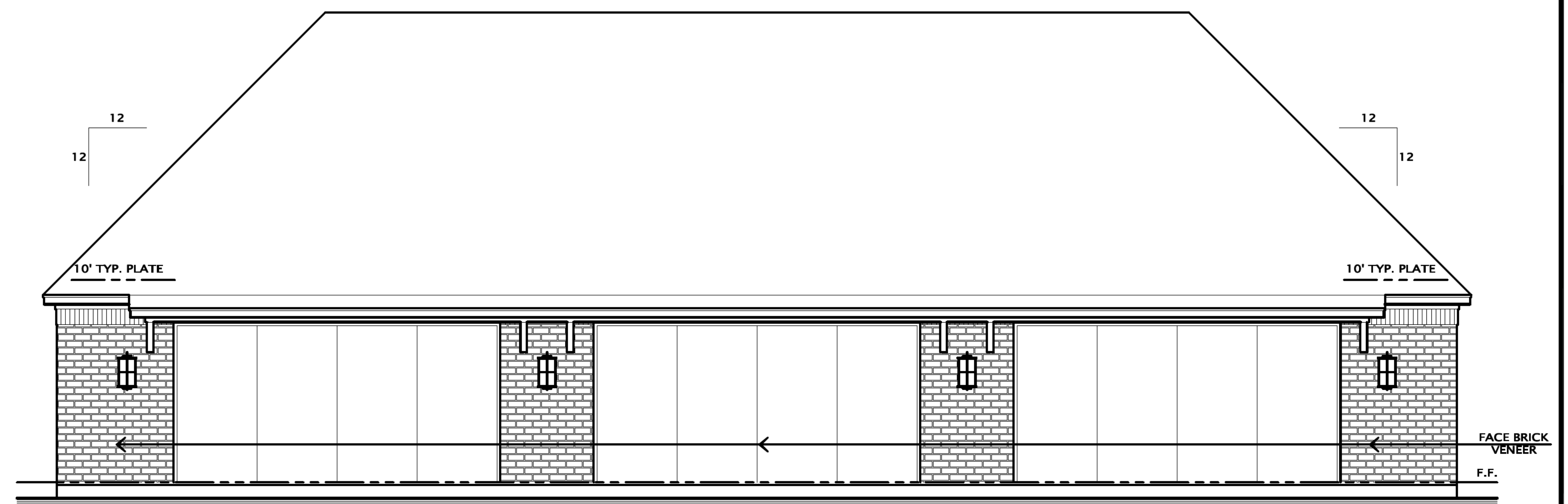

REAR ELEVATION

SCALE: 1/4" = 1'-0"

October 8th, 2025

--Neighbor Review & Comments To Planned Home Addition--

Note below regarding planned improvement address:

Brian & Amy Steffek
4905 Beldon Trail
Colleyville, TX 76034

Direct neighboring property to the north:

Don Ferrando
4901 Beldon Trail
Colleyville, TX 76034

To Whom It May Concern,

I, Don Ferrando, have reviewed with my neighbor, Brian Steffek, at his request, the architectural drawings and 3D model pictures for his planned ~1,900 sf foundation, one-story structure his family would like to build in his backyard. I appreciate Brian taking the time to ask my opinion and go through the details with me.

After my review with Brian, I support the project. I believe this improvement will be a welcomed addition for his active young family.

Sincerely,

A handwritten signature in cursive script that reads "Don Ferrando". The signature is written in black ink and has a long, sweeping flourish at the end.

Don Ferrando

 [Inbox](#)4905 Submittal for Archi...  

From: George Grubbs Jr. [REDACTED]
Sent: Thursday, October 9, 2025 7:51 AM
To: Brian Steffek [REDACTED]
Subject: Re: 4905 Submittal for Architectural Control Committee

Brian,

As a board member, I have approved your request and think it was well planned and well presented. Thanks for the details and for checking with Don. Look forwards to meeting you soon.

George Grubbs, Jr.
4809 Beldon Trail
[REDACTED]

From: Brian Steffek
[REDACTED]

Date: Thursday, October 9, 2025 at 6:54 AM
To: Jyothi Chennu [REDACTED]
Cc: Frank McDonald

[REDACTED] George Grubbs
[REDACTED] Jr. [REDACTED] Mike Risley
[REDACTED]

Subject: Re: 4905 Submittal for Architectural Control Committee

Addition letter from Don Ferrando supporting the project as my neighbor. The city said this is good to have and shows due diligence.

Brian

Get [Outlook for iOS](#)

From: Brian Steffek [REDACTED]
Sent: Wednesday, October 8, 2025 9:45:20 AM
To: Jyothi Chennu [REDACTED]
Cc: Frank McDonald [REDACTED]



Notification Map

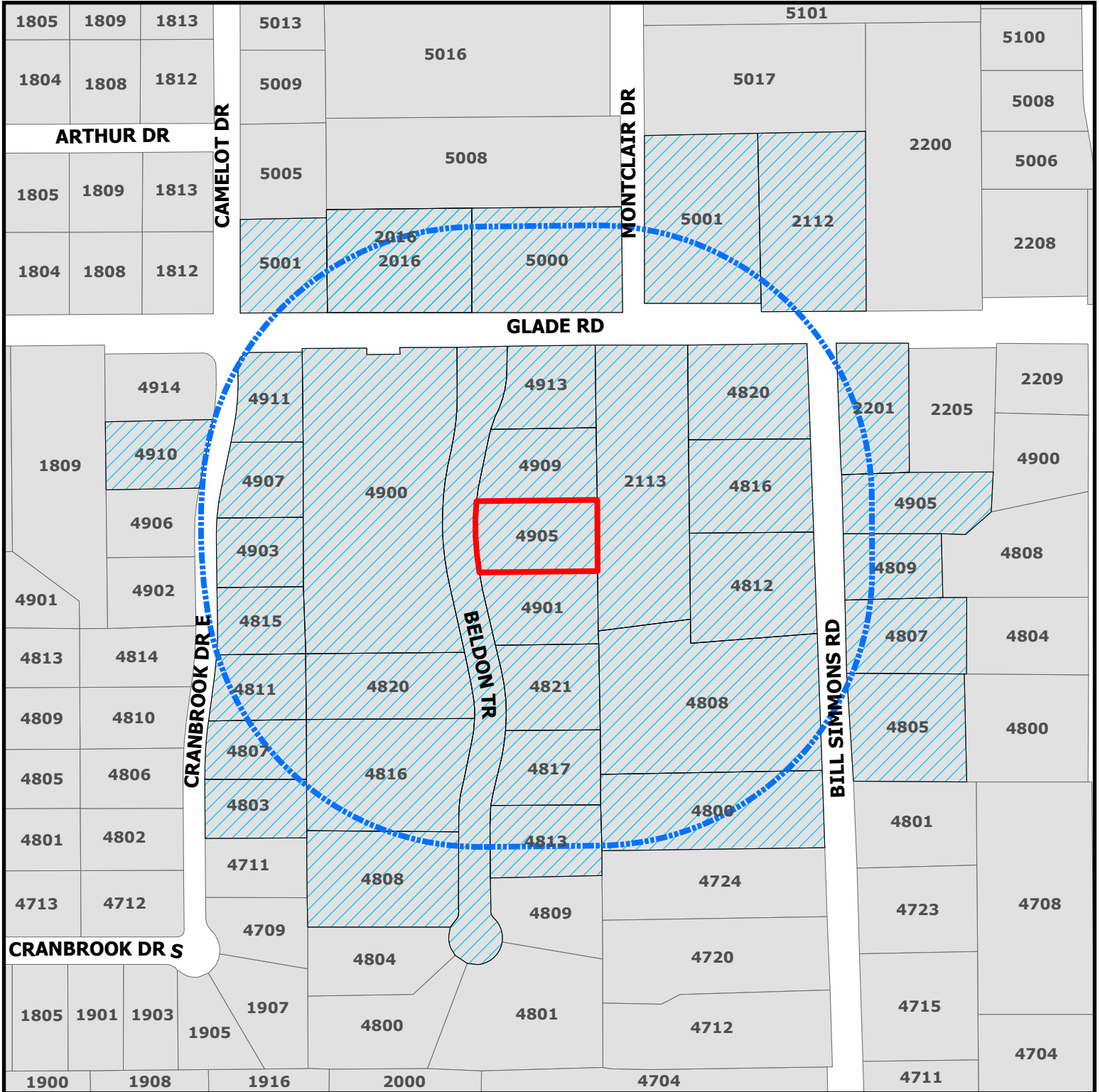



ZC25-029

4905 Beldon Trail



DISCLAIMER:
 This map and information contained in it were developed exclusively for use by the City of Colleyville. Any use or reliance on this map by anyone else is at that party's risk and without liability to the City of Colleyville, its officials or employees for any discrepancies, errors, or variances which may exist.

-  Subject Property
-  Buffer
-  Parcels to be notified

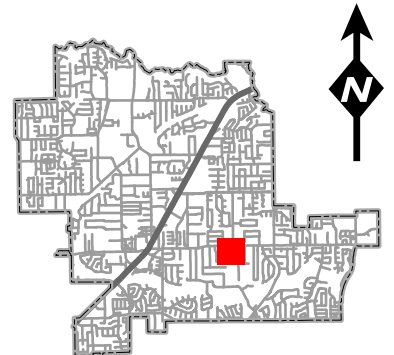



NOTICE OF PUBLIC HEARING

«Owner Name»

«Owner Address»

«Owner City» «Owner Zip»

The City of Colleyville has scheduled public hearings concerning the below referenced request on the following dates and location:

Planning and Zoning Commission Meeting: Monday, November 10, 2025 at 7:00p.m.
City Council Meetings: Tuesday, December 2, 2025 & Tuesday, December 16, 2025 at 7:00p.m.
3rd floor of City Hall, 100 Main Street, Colleyville, Texas

Request: Consideration of a Special Use Permit (SUP) for an Accessory Building on Lot 3, Block 1, Beldon Hollow, located at 4905 Beldon Trail, Case ZC25-029. The applicant is requesting the Special Use Permit to allow for an accessory building exceeding the size permitted by the Land Development Code. Per Section 3.27, an application to exceed the total square footage authorized may be approved as a Special Use Permit.

Zoning Case: ZC25-029

Applicant: Rodney Owens

Owner: Brian Steffek

Location: 4905 Beldon Trail

Property Description: Lot 3, Block 1, Beldon Hollow

Present Zoning: PUD-R Planned Unit Development – Residential

This notice has been sent to all owners of real property within 500 feet of the request as such ownership appears on the last approved tax roll and all homeowners' associations within 1000 feet. Approval by the Planning and Zoning Commission serves as a recommendation to the City Council and is not a final action on the request. Denial of the proposal by the Commission is final, unless the applicant submits a written notice of appeal within 10 days from the date of action by the Commission. If appealed, the request will be placed on the next available City Council agenda as listed above. Rezoning requests, zoning amendments and conditions recommended by the Commission for approval by the City Council may be more restrictive than those described in this notice.

All interested persons are encouraged to attend the public hearing and express their opinions on the zoning change request. If you are unable to attend, but wish to have your opinions made a part of the public record, please submit written comments prior to the public hearing, to the address or email below:

Community Development Department
City of Colleyville
100 Main Street
Colleyville, TX 76034
Citizenletters@colleyville.com

NOTICE OF PUBLIC HEARING

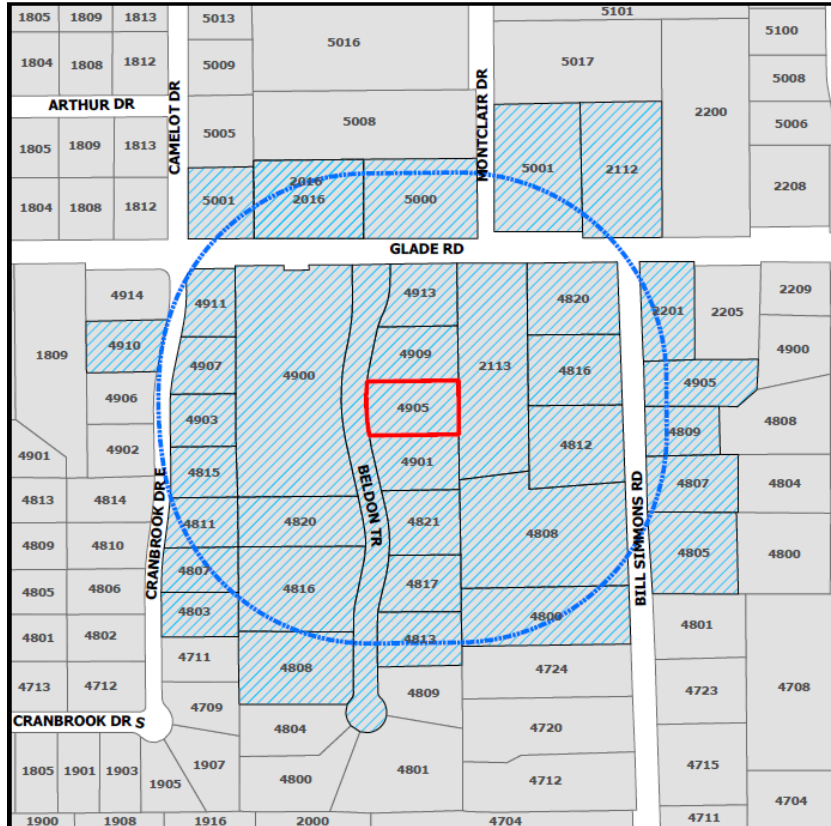

If the property owners of 20 percent or more of the land within the 200 foot notification area file a written protest prior to the public hearing, State law provides that the approval of the zoning change request shall require the approval of a super majority vote by City Council.

The application is on file for public examination in the Community Development Department at 100 Main Street, Colleyville, Texas 76034. A brief project description can be found online on the Agenda Packet and Active Development Case map (please use your phone’s camera to scan QR code below):

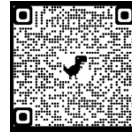

For additional information, please contact the Community Development Department at 817.503.1050. Please reference the zoning case number when requesting information.

Chris Pham

Chris Pham
Planner

ORDINANCE O-25-2356

AMENDING THE ZONING ON APPROXIMATELY 0.66 ACRES, BEING LOT 3, BLOCK 1, BELDON HOLLOW, LOCATED AT 4905 BELDON TRAIL, BY AUTHORIZING A SPECIAL USE PERMIT TO ALLOW FOR AN ACCESSORY BUILDING; PROVIDING A PENALTY OF FINE NOT TO EXCEED THE SUM OF TWO THOUSAND DOLLARS (\$2,000.00) AND PROVIDING AN EFFECTIVE DATE

WHEREAS, the City of Colleyville has received a request for a Special Use Permit (Case ZC25-029) to allow for an accessory building for the real property described as Lot 3, Block 1, Beldon Hollow, located at 4905 Beldon Trail, as further described and depicted on Exhibit "A" hereto (the "Subject Property"); and

WHEREAS, the Subject Property is presently zoned PUD-R Planned Unit Development - Residential; and

WHEREAS, the Planning and Zoning Commission of the City of Colleyville, has considered and made recommendations on the request, having given the requisite notices, and having held due hearings and affording a full and fair opportunity for all persons interested in the matter to be heard; and

WHEREAS, after due deliberations and consideration of the recommendation of the Planning and Zoning Commission, the information received at a public hearing, and other relevant information and materials, the City Council finds that this amendment is in conformance with the Comprehensive Plan for the City of Colleyville and promotes the general health, safety, and welfare of this community.

NOW, THEREFORE, BE IT ORDAINED BY THE CITY COUNCIL OF THE CITY OF COLLEYVILLE, TEXAS:

Sec. 1. THAT the foregoing premises and findings are found to be true and correct and are incorporated as if fully set forth herein.

Sec. 2. THAT the Comprehensive Zoning Ordinance of the City of Colleyville, Texas, be, and the same is hereby amended by changing the zoning on the Subject Property, by authorizing a Special Use Permit to allow for an accessory building, as depicted.

Sec. 3. THAT the above described tract of land shall be used only in the manner and for the purposes provided by the City's Comprehensive Zoning Ordinance and Land Development Code, as amended herein.

Sec. 4. THAT the above described tract of land shall be subject to the following conditions:

1. GENERAL

a. The Special Use Permit shall allow for the construction of an accessory building measuring 20 feet by 70 feet.

b. It shall be consistent with the elevations and as depicted on the attached Exhibit "B".

c. All requirements of the Land Development Code shall be met, except where amended herein.

Sec. 5. THAT any person, firm, or corporation violating any of the provisions or terms of this ordinance shall be subject to the same penalty as provided for in the Comprehensive Zoning Ordinance, as heretofore amended, and upon conviction shall be punished by a fine set in accordance with Chapter 1, Section 1-6 of the Code of Ordinances for the City of Colleyville.

Sec. 6. THAT in addition to and accumulative of all other penalties, the City shall have the right to seek injunctive relief for any and all violations of this ordinance.

Sec. 7. THAT if any section, paragraph, subdivision, clause, phrase or provision of this ordinance shall be judged invalid or unconstitutional, the same shall not affect the validity of this ordinance as a whole or any portion thereof other than that portion so decided to be invalid or unconstitutional.

Sec. 8. THAT this ordinance shall take effect immediately from and after its passage subject to the publication of the caption, as the law or charter in such cases may provide.

AND IT IS SO ORDERED.

The first reading and public hearing being conducted on the 2nd day of December 2025.

The second reading and public hearing being conducted on the 16th day of December 2025.

APPROVED BY A VOTE OF ____ AYES AND ____ NAYS ON THIS THE 16TH DAY OF DECEMBER 2025.

Mayor Bobby Lindamood	_____	Mark Alphonso, Place 2	_____
Mayor Pro Tem Brandi Elder	_____	Ben Graves, Place 4	_____
Deputy Mayor Pro Tem Scotty Richardson	_____	Tim Raine, Place 6	_____
Kimberly Holt Gunderson, Place 5	_____		

ATTEST:

CITY OF COLLEYVILLE

Christine Loven, TRMC
City Secretary

Bobby Lindamood
Mayor

APPROVED AS TO FORM:

Whitt Wyatt
City Attorney

Exhibit "A" – Aerial Map

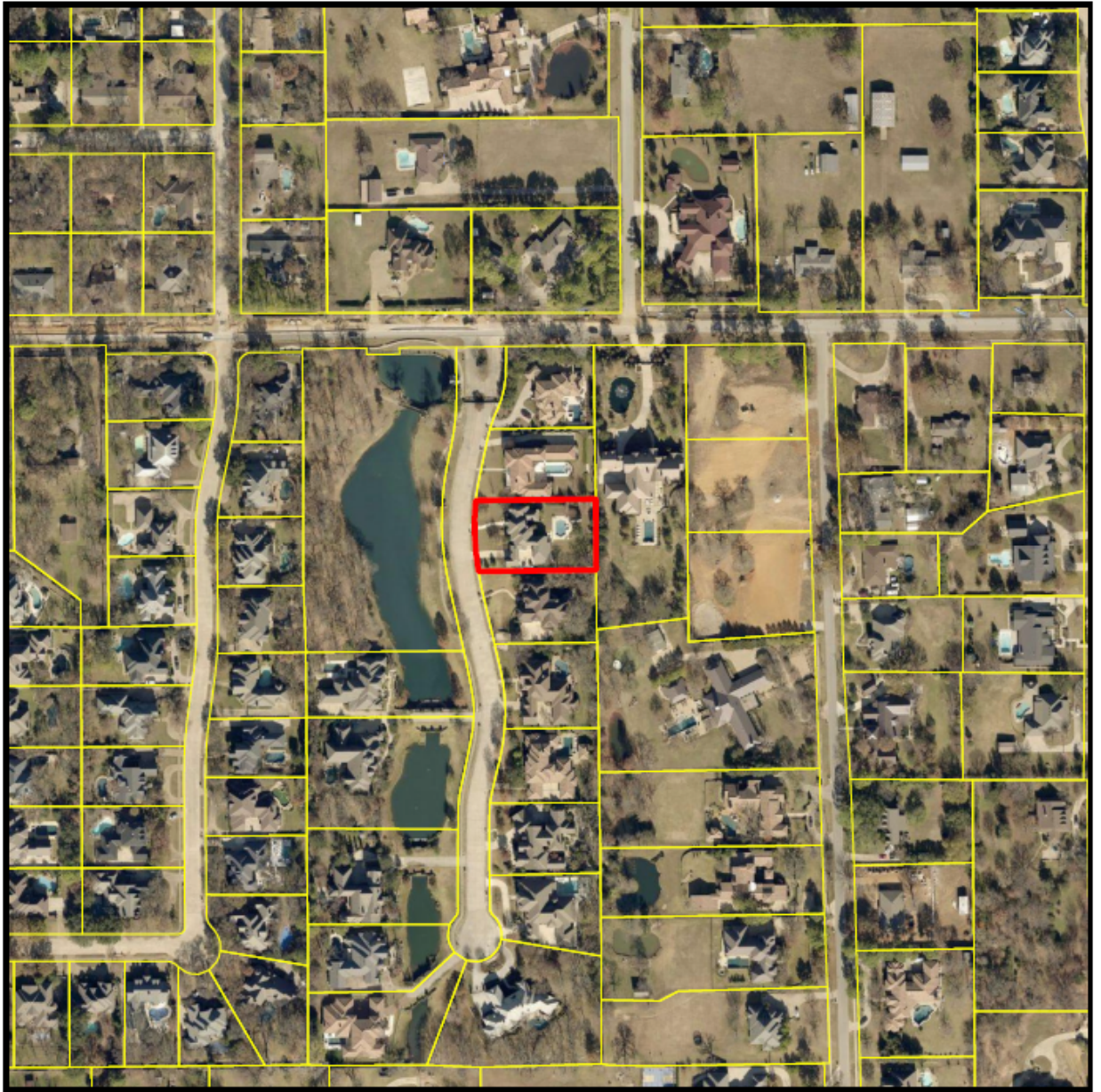
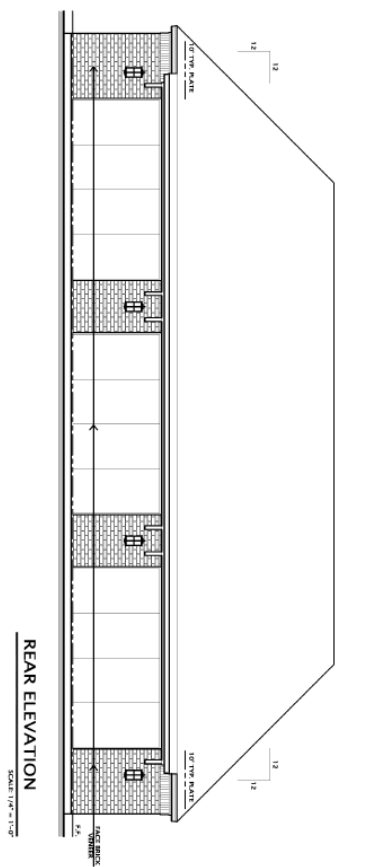
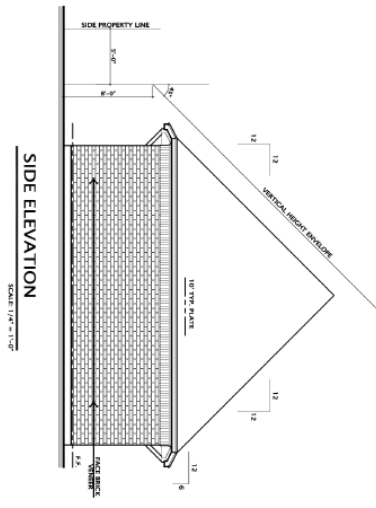
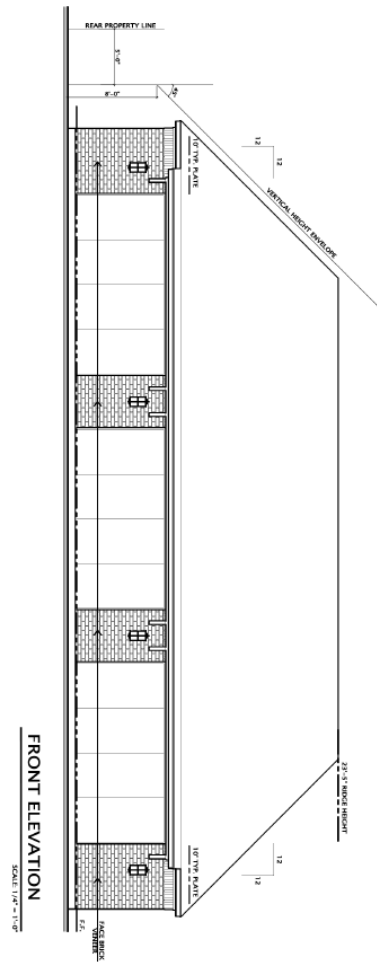
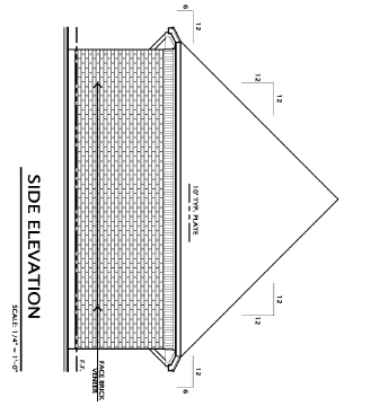

Exhibit "B" - Elevations



A.1 OF 2 SHEETS	STEFFEK GYM BUILDER CUSTOM HOMES	LOT 3 BLOCK 1 4905 BELDON TR. COLLEYVILLE, TX	THE DESIGN STUDIO OF JAMIE LINN	817-733-7173
	DATE: 11/15/2023 SHEET NO.: 2309-0001			





CITY OF COLLEYVILLE CITY COUNCIL BRIEFING

Agenda Number 8

Agenda Date 12/16/2025

Type Report

Department City Secretary

Title

Colleyville Center Advisory Committee Minutes — August 17, 2025

Planning and Zoning Commission Minutes — November 10, 2025

Planning and Zoning Commission Worksession Minutes — November 24, 2025

Attachments

1. Colleyville Center Advisory Committee Minutes - August 17, 2025
2. Planning and Zoning Commission Minutes — November 10, 2025
3. Planning and Zoning Commission Worksession Minutes — November 24, 2025



**CITY OF COLLEYVILLE
COLLEYVILLE CENTER
ADVISORY COMMITTEE
MINUTES**

5301 Riverwalk Drive

MONDAY, AUGUST 11, 2025 - 5:30 PM

PRESENT: Judith Goodwin; Lee Koch; Fred Mills, Chair; Emily Aguilar; Alex Thomas; Paul Vigiletti; Louis Miller; Darla Dennison; Kristi Isbell, Asst. Venue Manager; Chelsea Rose, Manager of Colleyville Center and Colleyville Business Center

ABSENT: Ann Morgan; Jessica Harig; Chris Carlson

1. CALL TO ORDER

The meeting was called to order by Fred Mills at 5:35 p.m.

2. APPROVAL OF MINUTES

Lee Koch motioned for approval of the May 19, 2025 minutes. Darla Dennison seconded the motion. The motion was approved with no dissension.

3. REGULAR AGENDA ITEMS

3a Budget and Utilization Update

Chelsea Rose provided a review of utilization that compared May – July of 2024 to the same months in 2025. Rose noted that utilization of bookable days increased from 63% to 83% year over year and that the guest count remained in similar ranges with 4,429 guests in May – July 2025. Darla Dennison asked for clarification on bookable days and Kristi Isbell explained that the reference is used for days the Center is available for a booking. Isbell noted that factors such as holidays, building maintenance and repair, and other schedules determine whether a day is “bookable.” Rose displayed photos of events from the busy spring season and described the various banquets, galas, and weddings hosted during this season. Rose noted that a future focus of marketing will be to remind community of the versatility of the space for celebrations of love, life, school, and business.

3b Community Engagement and Marketing Update

Rose discussed recent marketing opportunities with GCISD’s Education Foundation and the annual GCISD New Educator Luncheon and the GCISD Leadership Breakfast and explained that supporting events with our school district builds community connections while keeping Colleyville Center in mind for teachers and staff booking

events for their school. Rose noted that the Colleyville Center hosted the regional meeting for Texas Association of Venues and Facilities (TxAVF), an organization of which the Colleyville Center has been a member for over 10 years.

Rose provided information and samples of social media posts and viewer engagement trends that produced an increase of views by 17.2% over the last 60 days. Rose noted that some of the highest interaction has been for posts about the Colleyville Business Center. Rose indicated that a goal would be to include more video content on social media in order to increase views. Discussion ensued on various ideas for video type posts. Alex Thomas suggested creating a video from photo submissions set to music and Emily Aguilar suggested time-lapse type videos of set up through tear down to capture the transformation of the Grand Hall for an event. Rose reminded of the Colleyville Center's new Virtual Tour "button" on the webpage and described the usefulness, thus far, and positive feedback on this type of remote view of the Center.

Rose reminded members about the ongoing Colleyopoly program and how it serves as a community engagement device by bringing "feet in the door" traffic, sometimes with residents previously unfamiliar with the Colleyville Center. Rose explained the program also provides valuable interaction with residents that help in the creation of future community engagement programs. Rose noted that due to the positive feedback on Business BINGO, the Restaurant Roadmap, and Colleyopoly, the Colleyville Center would likely have a similar program with future Gift Card campaigns.

3c Update on Facility Maintenance and Improvements

Rose described the closeout of the installation of the new A/V system. Regarding the window and wall repair project, Rose explained that a City engineer and contracted architect are facilitating the project and required financial processes. Rose indicated that the Center is scheduled to have individual windows replaced this week to address cosmetic issues in the interim as one of these discolored windows is in a prominent location on the east wall.

Rose explained that one of the oldest HVAC units stopped working in June and required an emergency replacement. Rose provided photos and described all that was coordinated to remove, install, and replace the unit. Rose stated that although there was some reconfiguring of scheduled events, this installation occurred during the same block of time originally reserved for the window and wall repair project. Additionally, Rose noted that another HVAC unit's condensation trap overflowed on a weekend in July, without events, and required a separate repair and new ceiling tiles.

Rose provided an update on the sister property, the Colleyville Business Center (CBC), and encouraged Advisory members to visit and see the new space. Rose described the Colleyville Chamber's relationship with the CBC. Rose explained that the CBC can provide a "launch pad" for new businesses or those unsure whether

ready for a long-term operation on own site and that the CBC serves as part of a strategic effort for growth in The Village at Colleyville. Rose said that two suites and two offices are occupied with two offices available.

3d Discussion of Items for Future Agendas

No other items were presented for future agendas. Rose explained that new state legislative changes necessitate a review and update of the Bylaws of the Colleyville Center Advisory Committee. Rose explained that the meeting schedule will be reduced from four meetings per year, to two meetings per year but these may be formatted for two mandatory meeting dates and two "as-needed" dates. Rose indicated that the Bylaws have not changed yet and provided the dates for upcoming Colleyville Center Advisory Committee meetings: November 17, 2025 and February 16, 2026. The February 16, 2026 meeting will be held at the Colleyville Business Center located at 35 Veranda Lane.

4. ADJOURNMENT

Lee Koch motioned to adjourn the meeting. Paul Vigiletti seconded the motion. The motion was approved with no dissension. The meeting was adjourned at 6:20 p.m.

APPROVED BY A VOTE OF 7 AYES, 0 NAYS, AND 0 ABSTENTIONS ON THIS THE 17TH DAY OF NOVEMBER, 2025.



CITY OF COLLEYVILLE PLANNING AND ZONING COMMISSION MINUTES

100 Main Street, Colleyville, Texas, 76034

MONDAY, NOVEMBER 10, 2025

CALL MEETING TO ORDER EXECUTIVE CONFERENCE ROOM

The City of Colleyville Planning and Zoning Pre Commission Meeting was called to order by Commissioner Jerome Obinabo on November 10, 2025, at 6:15 p.m.

Roll Call

Present: Candace Sandifer, Jerry Savoie, Richard Remley, David Ebert, Jerome Obinabo, and Brandon Arnold.

Absent: David Groves

Staff Present: Community Development Director Ben Bryner, Planning Manager Daniel Ponder, Planner/Urban Forester Ivana Gonzalez, and Planner Bethany Lopez.

Planner Bethany Lopez briefed the Commission on the item that would be presented on tonight's agenda. There was general discussion regarding the updates to the case the Commission would be voting on.

Jerome Obinabo adjourned the Planning and Zoning Pre Commission Meeting at 6:23 p.m.

CALL MEETING TO ORDER CITY COUNCIL CHAMBERS

The City of Colleyville Planning and Zoning Commission Meeting was called to order by Jerome Obinabo on November 10, 2025, at 7:00 p.m.

Roll Call

Present: Candace Sandifer, Jerry Savoie, Richard Remley, David Ebert, Jerome Obinabo, and Brandon Arnold.

Absent: David Groves

Staff Present: Community Development Director Ben Bryner, Planning Manager Daniel Ponder, Planner/Urban Forester Ivana Gonzalez, and Planner Bethany Lopez.

1. APPROVAL OF MINUTES

- 1a** October 13, 2025, Planning and Zoning Commission Meeting Minutes
 October 27, 2025, Planning and Zoning Commission Worksession Meeting Minutes

Commissioner Savoie made a motion to approve the October 13, 2025 Planning and Zoning Commission Meeting Minutes and the October 27, 2025 Planning and Zoning Worksession meeting minutes, seconded by Commissioner Remley.

The motion was carried by the following vote:

Aye: 5 – Savoie, Obinabo, Arnold, Remley, and Ebert
Abstain: 1 – Sandifer
Nay: 0

2. PUBLIC HEARING AGENDA ITEMS

- 2a** Consideration of a Special Use Permit for an Accessory Building for Lot 3, Block 1, Beldon Hollow, located at 4905 Beldon Trail, Case ZC25-029

Planner Bethany Lopez presented case ZC25-029 and briefed the Commission on the request. The applicant is requesting the Special Use Permit to construct an Accessory Building that exceeds the 4% lot area permitted by the Land Development Code. Accessory Building meets all other code requirements.

Applicant Rodney Owens and owner Brian Steffek discussed their plans for use of the Accessory Building. They stated the building will be utilized as a multi-purpose area with a primary use for baseball training.

The public hearing was opened. With no one wishing to speak, the public hearing was closed.

Commissioner Savoie made a motion to approve case ZC25-029, seconded by Commissioner Arnold.

The motion was carried by the following vote:

Aye: 5 – Sandifer, Savoie, Obinabo, Arnold, and Ebert
Nay: 1 – Remley

3. CITIZEN COMMENTS

The public hearing was opened. With no one wishing to speak the public hearing was closed.

4. ADJOURNMENT

The meeting adjourned at 7:12 p.m.

The minutes were written and prepared by:

Ivana Gonzalez

Ivana Gonzalez
Planner/Urban Forester

The meeting minutes were approved on December 8, 2025, by a vote of 7-0.



CITY OF COLLEYVILLE PLANNING AND ZONING COMMISSION WORKSESSION MINUTES

100 Main Street, Colleyville, Texas, 76034

MONDAY, NOVEMBER 24, 2025

CALL MEETING TO ORDER EXECUTIVE CONFERENCE ROOM

The City of Colleyville Planning and Zoning Commission Worksession Meeting was called to order by Vice Chair Groves on November 24, 2025, at 6:15 p.m.

Roll Call

Present: David Groves, David Ebert, Richard Remley, Jerome Obinabo, Jerry Savoie, Brandon Arnold, and Candace Sandifer.

Staff Present: Planning Manager Daniel Ponder, Planner Christopher Pham, Planner/Urban Forester Ivana Gonzalez, Planner Bethany Lopez, and Fire Marshal Rob Mckeown.

2. WORKSESSION AGENDA ITEMS

2a Overview of Planning and Zoning Commission Considerations

City Attorney Sarah Ross presented an overview on the considerations for the Planning and Zoning Commission. Ross explained the roles of a commissioner and changes to the legislature.

3a Presentation and discussion of a replat for Lots 1R, 2R, and 5-7, Block 1, Northeast Professional Park, located at 1105 Professional Court and 5301 Colleyville Boulevard, Case PC25-022

Planning Manager Daniel Ponder presented the case and briefed the Commission on the request. There was discussion regarding the number of lots and requirements for the zoning district.

3. ADJOURNMENT

The meeting adjourned at 6:36 p.m.

The minutes were written and prepared by:

Bethany Lopez

Bethany Lopez
Planner

The meeting minutes were approved on December 8, 2025 by a vote of 7-0.

RESOLUTION R-25-5103

**A RESOLUTION APPROVING CITY COUNCIL ACTION UNDER
BUSINESS AT THE REGULAR CITY COUNCIL MEETING OF
DECEMBER 16, 2025**

WHEREAS, City Council has taken action on certain items on the agenda under Business.

NOW, THEREFORE, BE IT RESOLVED BY THE CITY COUNCIL OF THE CITY OF COLLEYVILLE, TEXAS:

Sec. 1. THAT

AND IT IS SO RESOLVED.

APPROVED BY A VOTE OF _ AYES, _ NAYS, ON THIS THE 16TH DAY OF DECEMBER 2025.

Mayor Bobby Lindamood	_____	Mark Alphonso, Place 2	_____
Mayor Pro Tem Brandi Elder	_____	Ben Graves, Place 4	_____
Deputy Mayor Pro Tem Scotty Richardson	_____	Tim Raine, Place 6	_____
Kimberly Holt Gunderson, Place 5	_____		

ATTEST:

CITY OF COLLEYVILLE

Christine Loven
City Secretary, TRMC

Bobby Lindamood
Mayor